

JVC

SERVICE MANUAL

MICRO COMPONENT SYSTEM

UX-V10GN

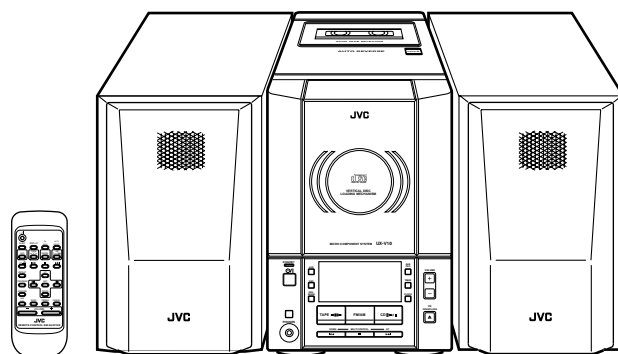

COMPACT
disc
DIGITAL AUDIO

Area Suffix

UF China
UN Indonesia

Contents

Safety precautions	1-2	Maintenance of laser pickup	1-20
Important for laser products	1-4	Replacement of laser pickup	1-20
Disassembly method	1-5	Description of major ICs	1-21
Main adjustment	1-15		
Flow of functional operation until TOC read	1-19		

Safety Precautions

1. This design of this product contains special hardware and many circuits and components specially for safety purposes. For continued protection, no changes should be made to the original design unless authorized in writing by the manufacturer. Replacement parts must be identical to those used in the original circuits. Services should be performed by qualified personnel only.
2. Alterations of the design or circuitry of the product should not be made. Any design alterations of the product should not be made. Any design alterations or additions will void the manufacturer's warranty and will further relieve the manufacture of responsibility for personal injury or property damage resulting therefrom.
3. Many electrical and mechanical parts in the products have special safety-related characteristics. These characteristics are often not evident from visual inspection nor can the protection afforded by them necessarily be obtained by using replacement components rated for higher voltage, wattage, etc. Replacement parts which have these special safety characteristics are identified in the Parts List of Service Manual. Electrical components having such features are identified by shading on the schematics and by (\triangle) on the Parts List in the Service Manual. The use of a substitute replacement which does not have the same safety characteristics as the recommended replacement parts shown in the Parts List of Service Manual may create shock, fire, or other hazards.
4. The leads in the products are routed and dressed with ties, clamps, tubings, barriers and the like to be separated from live parts, high temperature parts, moving parts and/or sharp edges for the prevention of electric shock and fire hazard. When service is required, the original lead routing and dress should be observed, and it should be confirmed that they have been returned to normal, after re-assembling.

5. Leakage current check (Electrical shock hazard testing)

After re-assembling the product, always perform an isolation check on the exposed metal parts of the product (antenna terminals, knobs, metal cabinet, screw heads, headphone jack, control shafts, etc.) to be sure the product is safe to operate without danger of electrical shock.

Do not use a line isolation transformer during this check.

- Plug the AC line cord directly into the AC outlet. Using a "Leakage Current Tester", measure the leakage current from each exposed metal parts of the cabinet, particularly any exposed metal part having a return path to the chassis, to a known good earth ground. Any leakage current must not exceed 0.5mA AC (r.m.s.)

- Alternate check method

Plug the AC line cord directly into the AC outlet. Use an AC voltmeter having, 1,000 ohms per volt or more sensitivity in the following manner. Connect a 1,500 Ω 10W resistor paralleled by a 0.15 μ F AC-type capacitor between an exposed metal part and a known good earth ground.

Measure the AC voltage across the resistor with the AC voltmeter.

Move the resistor connection to each exposed metal part, particularly any exposed metal part having a return path to the chassis, and measure the AC voltage across the resistor. Now, reverse the plug in the AC outlet and repeat each measurement. voltage measured Any must not exceed 0.75 V AC (r.m.s.). This corresponds to 0.5 mA AC (r.m.s.).

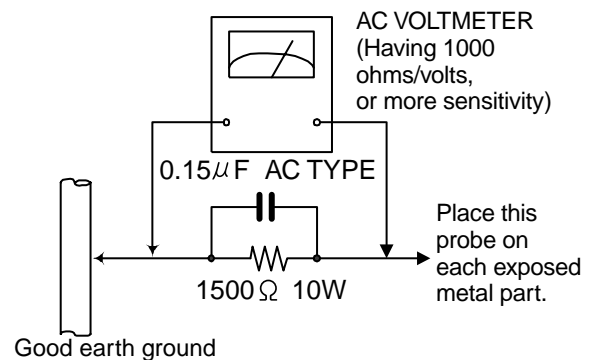

Warning

1. This equipment has been designed and manufactured to meet international safety standards.
2. It is the legal responsibility of the repairer to ensure that these safety standards are maintained.
3. Repairs must be made in accordance with the relevant safety standards.
4. It is essential that safety critical components are replaced by approved parts.
5. If mains voltage selector is provided, check setting for local voltage.

CAUTION Burrs formed during molding may be left over on some parts of the chassis. Therefore, pay attention to such burrs in the case of performing repair of this system.

Safety precautions (U.K only)

1. This design of this product contains special hardware and many circuits and components specially for safety purposes. For continued protection, no changes should be made to the original design unless authorized in writing by the manufacturer. Replacement parts must be identical to those used in the original circuits.
2. Any unauthorised design alterations or additions will void the manufacturer's guarantee ; furthermore the manufacturer cannot accept responsibility for personal injury or property damage resulting therefrom.
3. Essential safety critical components are identified by () on the Parts List and by shading on the schematics, and must never be replaced by parts other than those listed in the manual. Please note however that many electrical and mechanical parts in the product have special safety related characteristics. These characteristics are often not evident from visual inspection. Parts other than specified by the manufacturer may not have the same safety characteristics as the recommended replacement parts shown in the Parts List of the Service Manual and may create shock, fire, or other hazards.
4. The leads in the products are routed and dressed with ties, clamps, tubings, barriers and the like to be separated from live parts, high temperature parts, moving parts and/or sharp edges for the prevention of electric shock and fire hazard. When service is required, the original lead routing and dress should be observed, and it should be confirmed that they have been returned to normal, after re-assembling.

Warning

1. Service should be performed by qualified personnel only.
2. This equipment has been designed and manufactured to meet international safety standards.
3. It is the legal responsibility of the repairer to ensure that these safety standards are maintained.
4. Repairs must be made in accordance with the relevant safety standards.
5. It is essential that safety critical components are replaced by approved parts.
6. If mains voltage selector is provided, check setting for local voltage.

 **CAUTION** Burrs formed during molding may be left over on some parts of the chassis. Therefore, pay attention to such burrs in the case of performing repair of this system.

Important for laser products

1.CLASS 1 LASER PRODUCT

2.DANGER : Invisible laser radiation when open and inter lock failed or defeated. Avoid direct exposure to beam.

3.CAUTION : There are no serviceable parts inside the Laser Unit. Do not disassemble the Laser Unit. Replace the complete Laser Unit if it malfunctions.

4.CAUTION : The compact disc player uses invisible laserradiation and is equipped with safety switches which prevent emission of radiation when the drawer is open and the safety interlocks have failed or are defeated. It is dangerous to defeat the safety switches.

5.CAUTION : If safety switches malfunction, the laser is able to function.

6.CAUTION : Use of controls, adjustments or performance of procedures other than those specified herein may result in hazardous radiation exposure.

⚠ CAUTION Please use enough caution not to see the beam directly or touch it in case of an adjustment or operation check.

WARNING : Osynlig laserstrålning är denna del är öppnad och spårren är urkopplad. Betrakta ej strålen.

VARO : Avattaessa ja suojalukitus ohitettaessa olet alltiina näkymättömälle lasersäteilylle. Älä katso säteeseen.

ADVARSEL : Usynlig laserstrålning ved åbning , når sikkerhedsafbrydere er ude af funktion. Undgå udsættelse for stråling.

ADVARSEL : Usynlig laserstrålning ved åpning,når sikkerhetsbryteren er avslott. unngå utsettelse for stråling.

REPRODUCTION AND POSITION OF LABELS

WARNING LABEL

CLASS 1
LASER PRODUCT



Disassembly method

<Main body>

■ Removing the rear cover

(See Fig.1 and 2)

1. Remove the eight screws A attaching the rear cover on the back of the body.
2. Remove the two screws B attaching the rear cover on the bottom of the body.
3. Unlock the speaker terminal and the antenna terminal, then remove the rear cover backward with releasing the hooks.

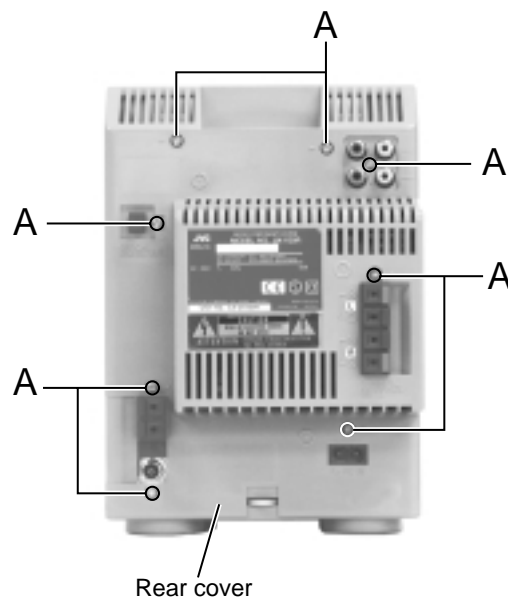

Fig.1

■ Removing the side panels

(See Fig.3 and 4)

- Prior to performing the following procedure, remove the rear cover.
1. Move the side panels in the direction of the arrow and remove them backward.

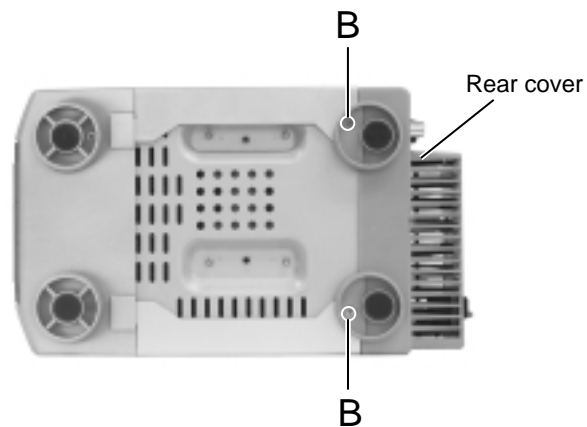

Fig.2

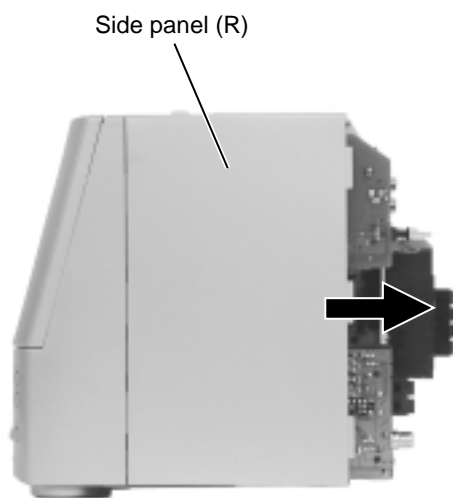

Fig.4

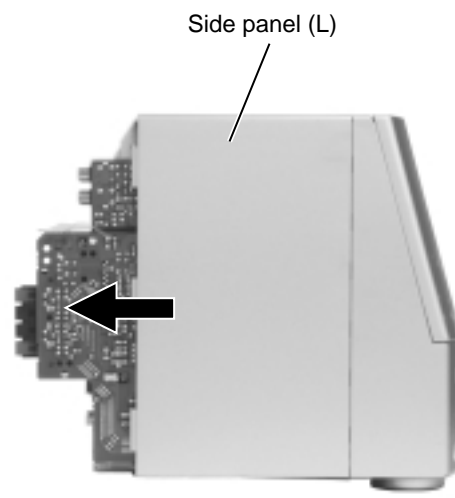

Fig.3

■Removing the cassette mechanism assembly (See Fig.5 and 6)

• Prior to performing the following procedure, remove the rear cover and the side panels.

1. Disconnect the card wires from connector CN304 and CN305 on the main board on the left side of the body.
2. Disconnect the harness from connector CN309 on the Opt, Dig.out board on the right side of the body. Cut off the band fixing the harness.
3. Remove the two screws C attaching the cassette mechanism assembly on both sides of the body and release the two joints a.
4. Remove the cassette mechanism assembly in the direction of the arrow.

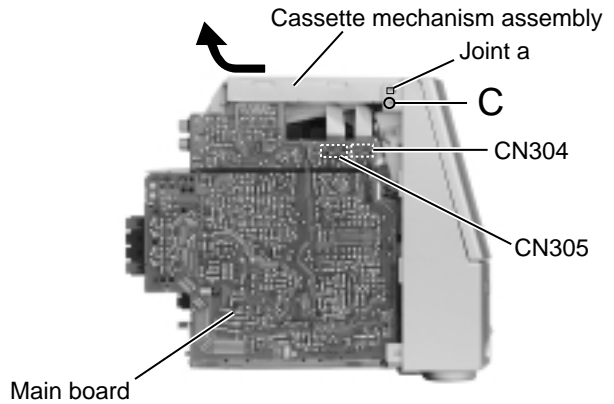

Fig.5

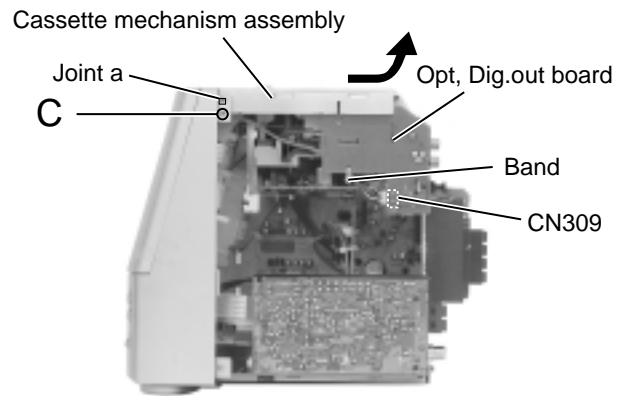

Fig.6

■Removing the main board / the heat sink (See Fig.7 to 9)

• Prior to performing the following procedure, remove the rear cover, the side panels and the cassette mechanism assembly.

1. Disconnect the card wire from connector CN303 and the harness from CN306 and CN307 on the main board respectively.
2. Disconnect the harness from connector CN902 on the power transformer.
3. Remove the screw E attaching the main board on the right side of the body.
4. Remove the screw F and the two screws G attaching the heat sink on the back of the body.

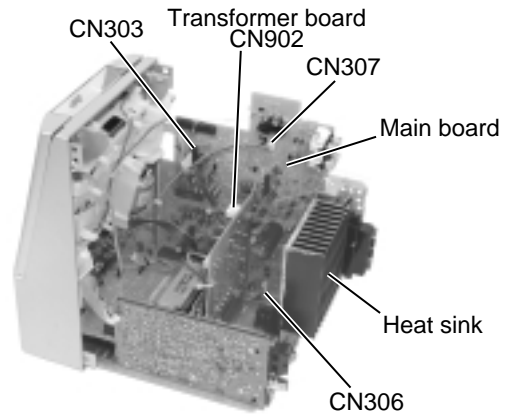

Fig.7

ATTENTION: The heat sink can be removed even if the main board is attached to the body.

5. Disconnect connector CN301 and CN302 on the main board from the main body. Remove the main board upward by releasing the two joints b in the lower part of the main board.

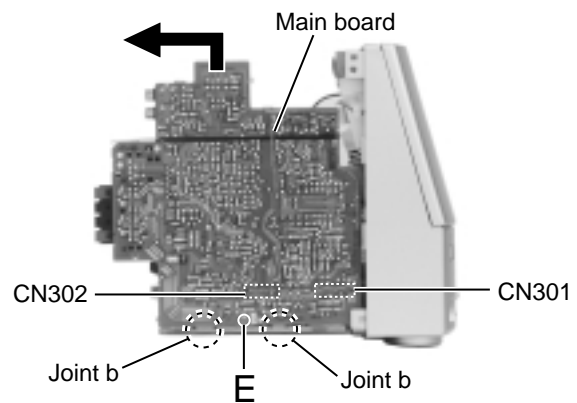

Fig.8

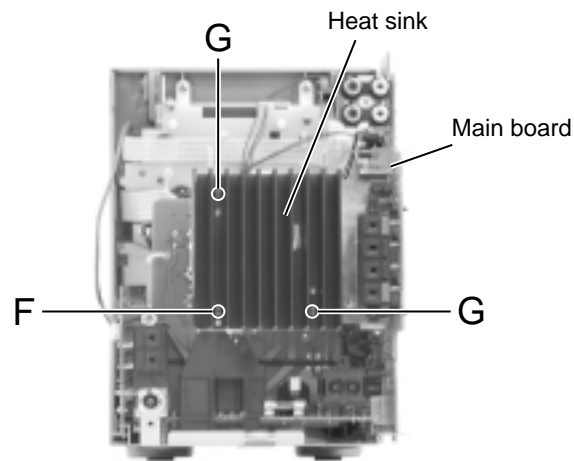

Fig.9

**■ Removing the front panel assembly
(See Fig.10 to 12)**

• Prior to performing the following procedure, remove the rear cover, the side panels, the cassette mechanism assembly and the main board.

1. Disconnect the card wire from connector CN732 on the LCD board.
2. Remove the two screws D attaching the front panel assembly on the bottom of the body.
3. Release the two joints c on the lower right and left sides of the body. Pull out the front panel assembly toward the front.

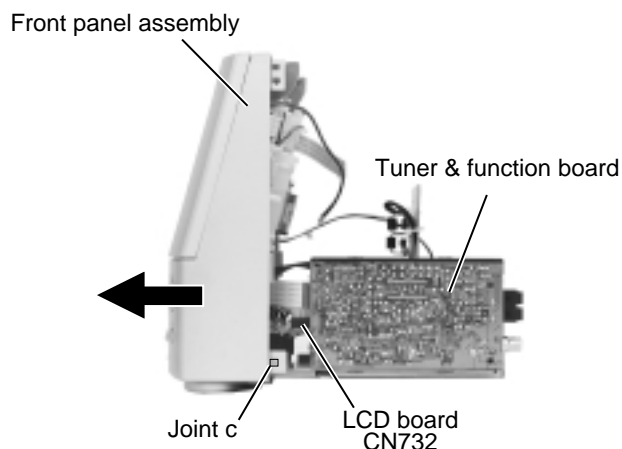

Fig.10

**■ Removing the head phone board
(See Fig.13)**

• Prior to performing the following procedure, remove the rear cover, the side panels, the cassette mechanism assembly, the main board and the front panel assembly.

1. Remove the plastic rivet attaching the head phone board and release the joint d.

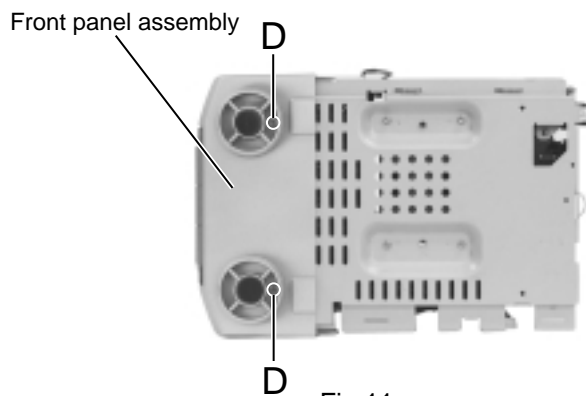

Fig.11

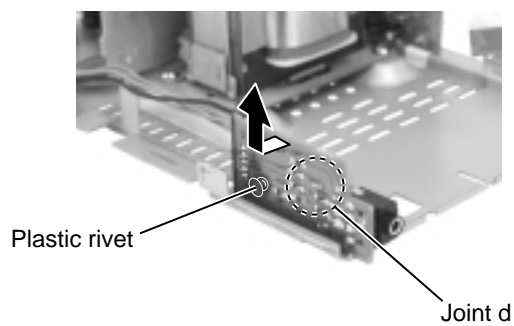

Fig.13

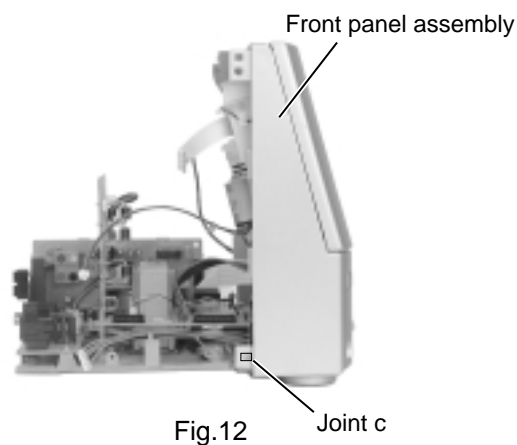

Fig.12

■ Removing the tuner & function board
(See Fig.14)

- Prior to performing the following procedure, remove the rear cover, the side panels and the cassette mechanism assembly.
1. Disconnect the card wire from connector CN1 on the tuner & function board.
 2. Remove the screw H attaching the tuner & function board.
 3. Release the two joints e and the joint f of the tuner & function board.

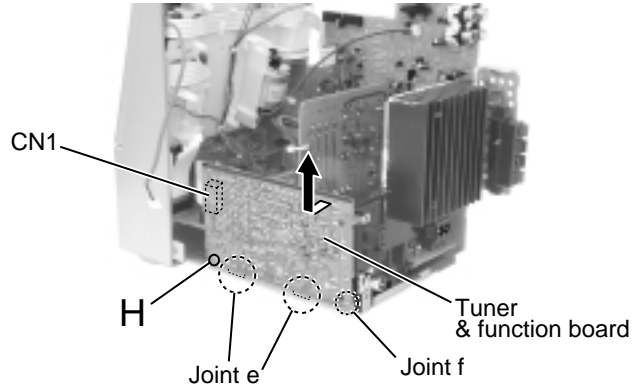

Fig.14

■ Removing the power transformer
(See Fig.15)

- Prior to performing the following procedure, remove the rear cover, the side panels and the cassette mechanism assembly.
1. Disconnect the harness from connector CN902 on the power transformer.
 2. Disconnect the harness from connector CN901 on the AC supply board.
 3. Remove the four screws I attaching the power transformer.

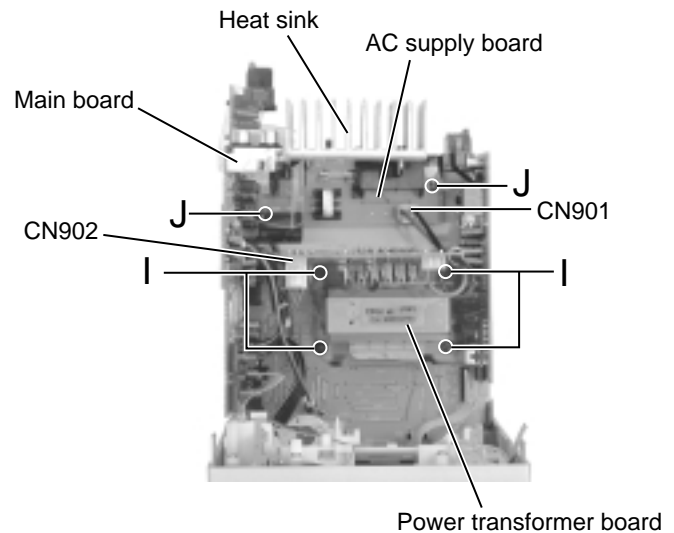

Fig.15

■ Removing the AC supply board
(See Fig.15)

- *Prior to performing the following procedure, remove the rear cover, the side panels and the cassette mechanism assembly.
1. Disconnect the harness from connector CN901 on the AC supply board.
 2. Remove the screw F attaching the heat sink on the back of the body (Refer to Fig.9).
 3. Remove the two screws J attaching the AC supply board.

ATTENTION: To remove the AC supply board efficiently, remove the main board in advance.

<Cassette mechanism assembly>

- Prior to performing the following procedure, remove the rear cover, the side panels and the cassette mechanism assembly.

■ Removing the Opt.Dig.out board (See Fig.16)

1. Remove the two screws K attaching the Opt.Dig.out board on the side of the cassette mechanism assembly.

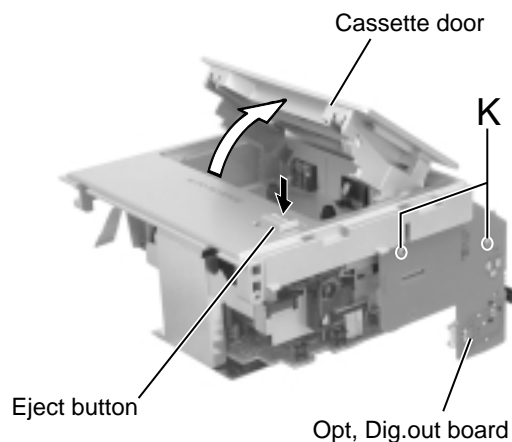

Fig.16

■ Removing the cassette mechanism assembly (See Fig.16 and 17)

- Prior to performing the following procedure, remove the Opt.Dig.out board.
1. Press the eject button on the front side of the cassette mechanism assembly to open the cassette door.
 2. Remove the four screws L attaching the cassette mechanism assembly on the back of the assembly.

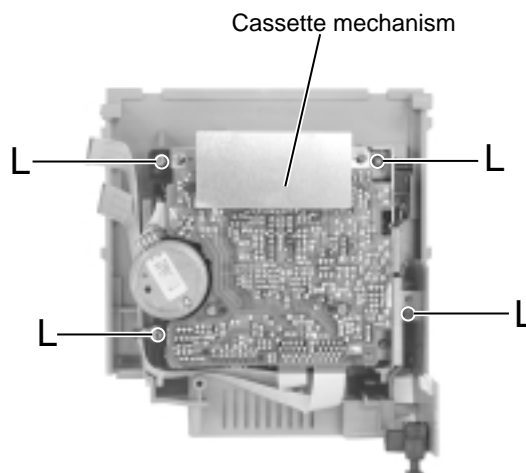

Fig.17

<Front panel assembly>

- Prior to performing the following procedure, remove the rear cover, the side panels, the cassette mechanism assembly, the main board and the front panel assembly.

■ Removing the CD mechanism assembly (See Fig.18 to 21)

1. Disconnect the harness from connector CN721 and CN722, and the card wire from CN766 on the LCD board on the back of the front panel assembly.
2. Remove the five screws M attaching the CD mechanism cover to the front panel. Remove the CD mechanism cover together with the CD mechanism assembly.
3. Release the harness from each hook on the CD mechanism cover.
4. Remove the five screws N attaching the CD mechanism cover and the CD mechanism case. Release the three joints g of the CD mechanism cover and the CD mechanism case by pushing the joint hooks inward.
5. Disconnect the card wire from connector CN603 and the harness from CN605 on the CD servo control board.
6. Remove the CD mechanism assembly from the CD mechanism cover by pulling out it from the three bosses h.

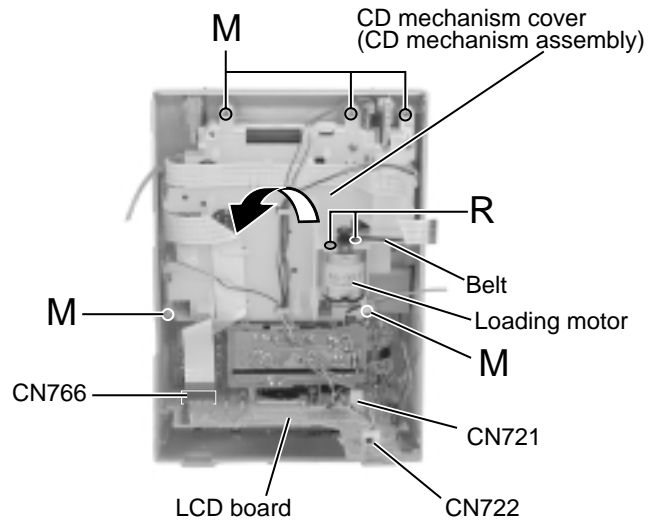

Fig.18

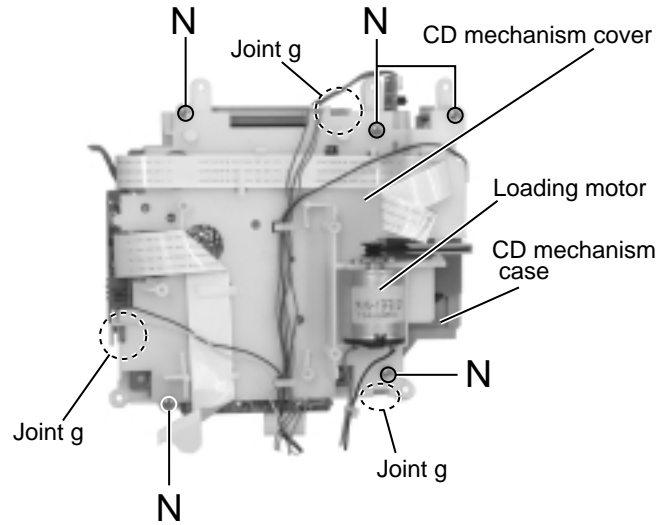

Fig.19

■ Removing the LED board (A) (See Fig.21)

1. Remove the screw O attaching the LED board (A).

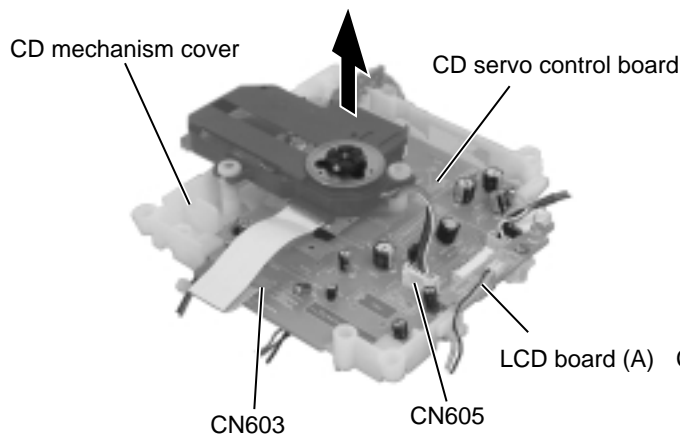

Fig.21

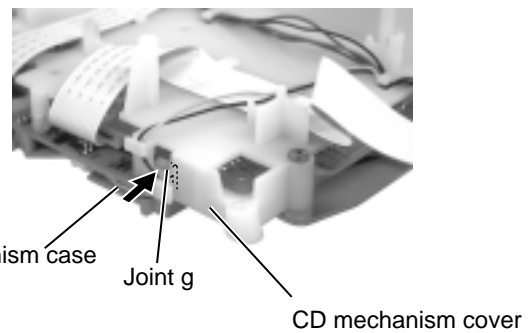

Fig.20

■ Removing the LED board (B) (See Fig.22)

- Prior to performing the following procedure, remove the CD mechanism assembly.

1. Remove the screw P attaching the LED board (B).

■ Removing the CD door switch board (See Fig.22)

1. Release the hook i fixing the CD door switch board to the CD mechanism cover.

■ Removing the CD servo control board (See Fig.22)

- Prior to performing the following procedure, remove the CD mechanism assembly and the LED board (A) / (B).

1. Remove the two screws Q attaching the CD servo control board.

2. Pull out the CD servo control board in the direction of the arrow by releasing the two joints j.

■ Removing the loading motor (See Fig.18)

1. Remove the belt and the two screws R attaching the loading motor on the back of the front panel assembly.

■ Removing the LCD board assembly (See Fig.23)

- Prior to performing the following procedure, remove the CD mechanism cover (CD mechanism assembly).

1. Remove the two screws S attaching the LCD board assembly.

2. Disconnect connector CN781 on the LCD board assembly from the operation switch board.

■ Removing the operation switch board (See Fig.24)

- Prior to performing the following procedure, remove the LCD board assembly.

1. Remove the eight screws T attaching the operation switch board.

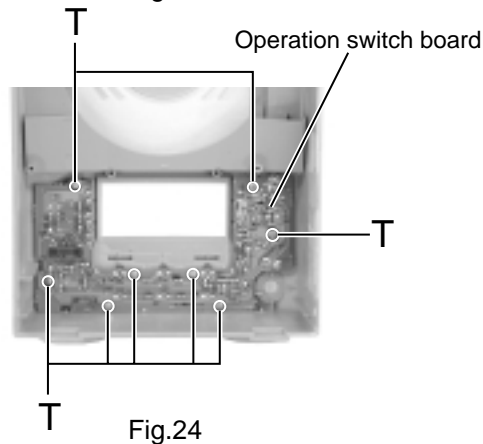
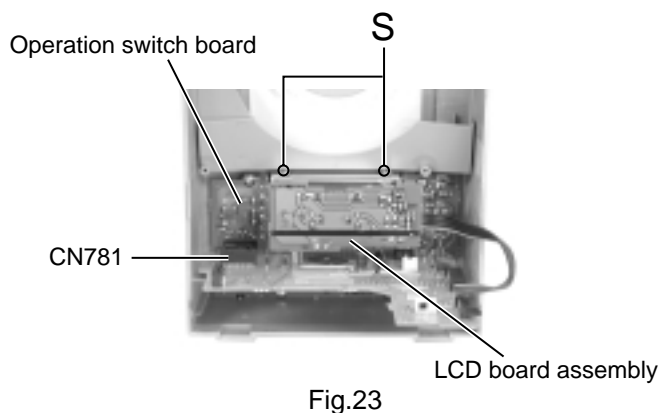
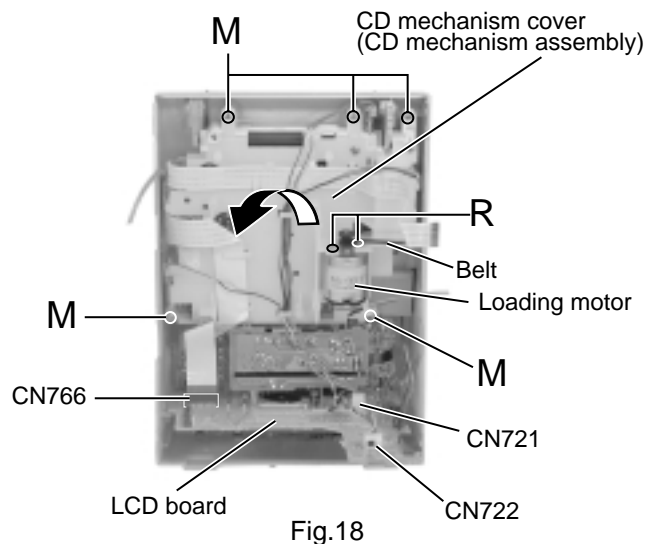
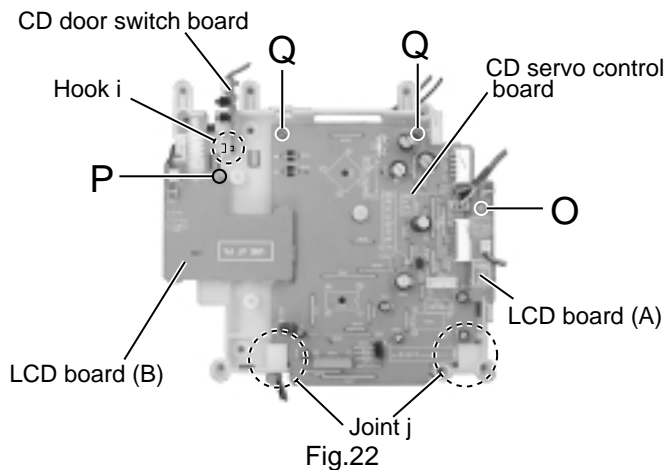

<<Cassette Mechanism Section>>

■ Removing the Playback/Recording & Eraser Head (See Figs. 1 and 2)

1. While shifting the trigger arms seen on the right side of the head mount in the arrow direction, turn the flywheel R in counterclockwise direction until the head mount has gone out with a click (See Fig. 1).
2. When the flywheel R is rotated in counterclockwise direction, the Playback/Recording & Eraser head will be turned in counterclockwise direction from the position in Fig. 2 to that in Fig. 3.
3. At this position, disconnect the flexible P.C. board (outgoing from the Playback/Recording & Eraser head) from the connector CN31 on the head amplifier & mechanism control P.C. board.
4. After dismantling the FPC holder, remove the flexible P.C. board.
5. Remove the flexible P.C. board from the chassis base.
6. Remove the spring Afro behind the Playback/Recording & Eraser head.
7. Loosen the reversing azimuth screw retaining the Playback /Recording & Eraser head.
8. Take out the Playback/Recording & Eraser head from the front of the head mount.
9. The Playback/Recording & Eraser head should also be removed similarly according to Steps 1 ~ 8 above.

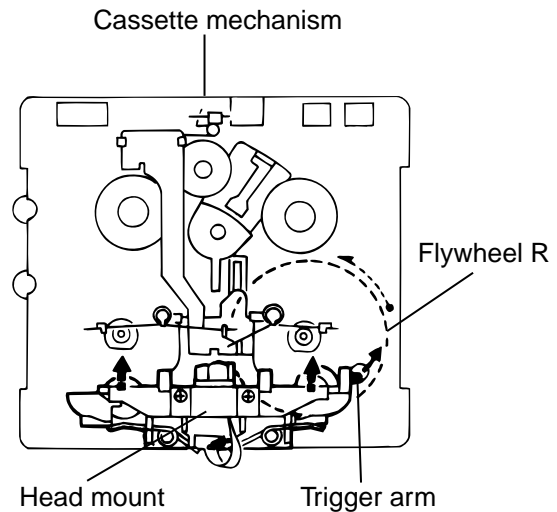

Fig. 1

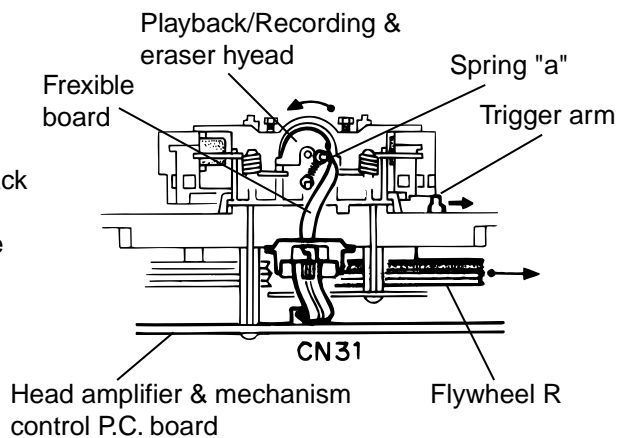

Fig. 2

■ Reassembling the Playback/Recording & Eraser Head

1. Reassemble the playback head from the front of the head mount to the position as shown in Fig. 3.
2. Fix the reversing azimuth screw.
3. Set the spring "a" from behind the Playback/Recording & Eraser head.
4. Attach the flexible P.C. board to the chassis base, and fix it with the FPC holder as shown in Fig. 3.
5. The Playback/Recording & Eraser head should also be reassembled similarly to Step 1 ~ 4 above.

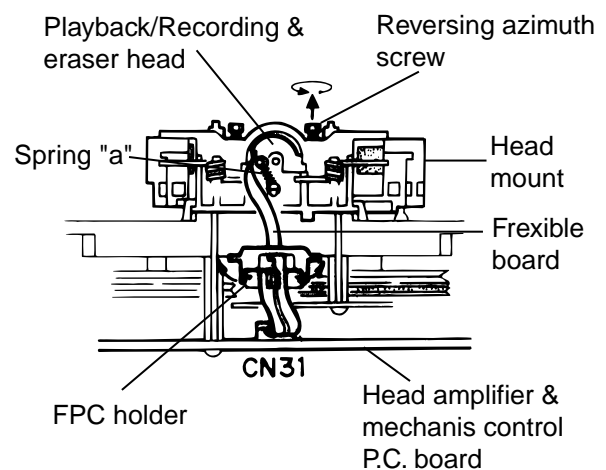
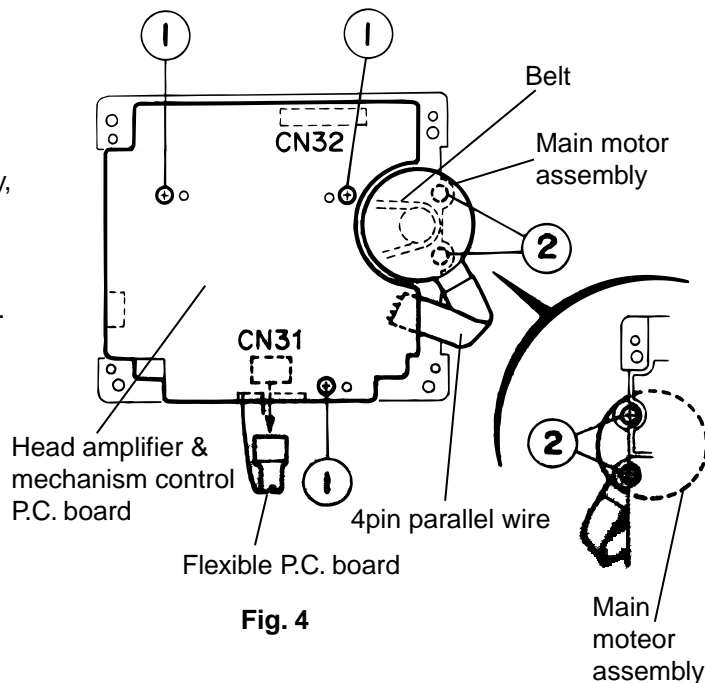

Fig. 3

■ Removing the Head amplifier & Mechanism control P.C. board

(See Fig. 4)

1. Remove the cassette mechanism assembly.
2. After turning over the cassette mechanism assembly, remove the three screws "1" retaining the head amplifier & mechanism control P.C. board.
3. Disconnect the connector CN32 on the P.C. board including the connector CN 1 on the reel pulse P.C. board.
4. When necessary, remove the 4 pin parallel wire soldered to the main motor.



■ Removing the Main Motor Assembly

(See Fig. 4-6)

1. Remove the two screws "2" retaining the main motor assembly (See Fig. 4, 4a).
2. While raising the main motor, remove the capstan belt from the motor pulley (See Fig. 4a).

Caution 1: Be sure to handle the capstan belt so carefully that this belt will not be stained by grease and other foreign matter. Moreover, this belt should be hanged while referring to the capstan belt hanging method in Fig. 5, 6.

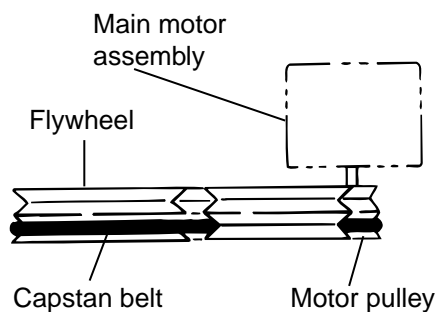
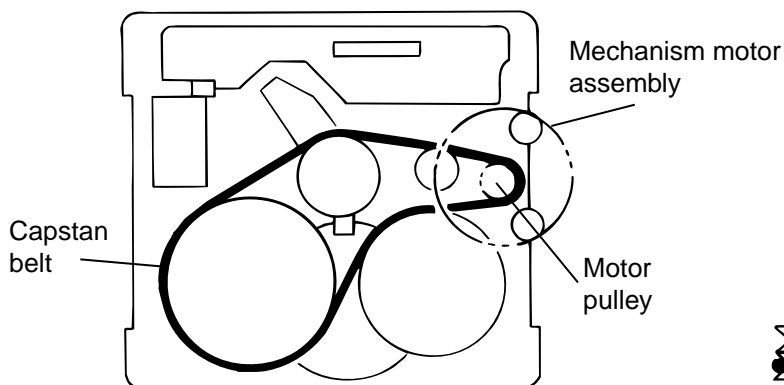
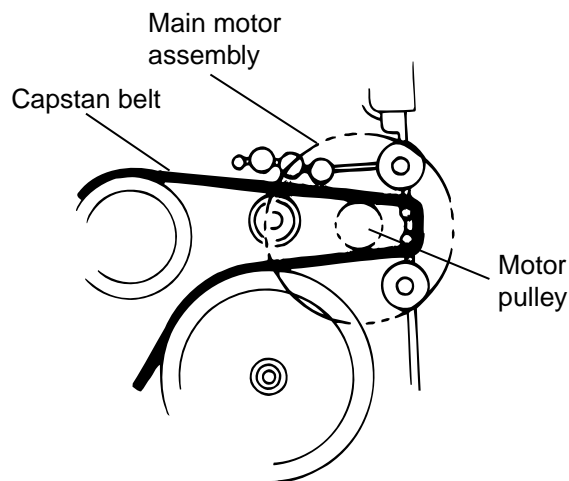

■ **Removing the Flywheel**

(See Figs. 7 and 8)

1. Remove the head amplifier & mechanism control P.C. board.
2. Remove the main motor assembly.
3. After turning over the cassette mechanism, remove the slit washers "b" and "c" fixing the capstan shafts R and L, and pull out the flywheel R and L respectively from behind the cassette mechanism.

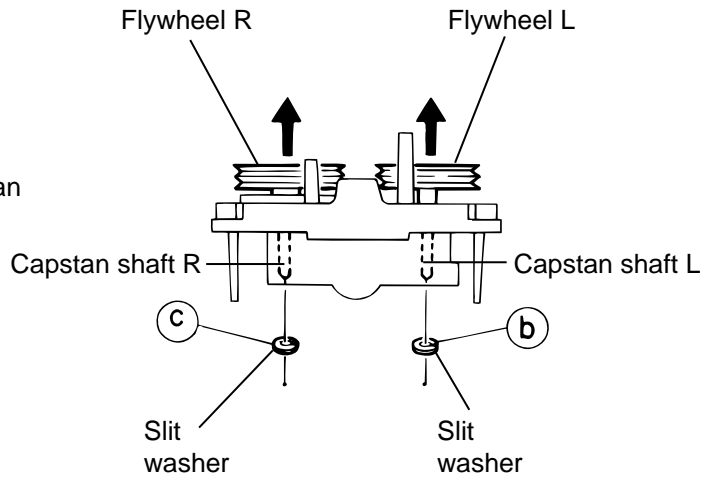

Fig.7

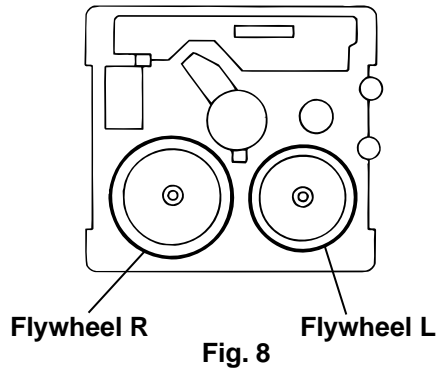

Fig. 8

■ **Removing the Reel Pulse P.C. board and Solenoid**

(See Fig. 9)

1. Remove the five pails "d"~"h" retaining the reel pulse P.C. board.
2. From the surface of the reel pulse P.C. board parts, remove the two pawls "i" and "j" retaining the solenoid.

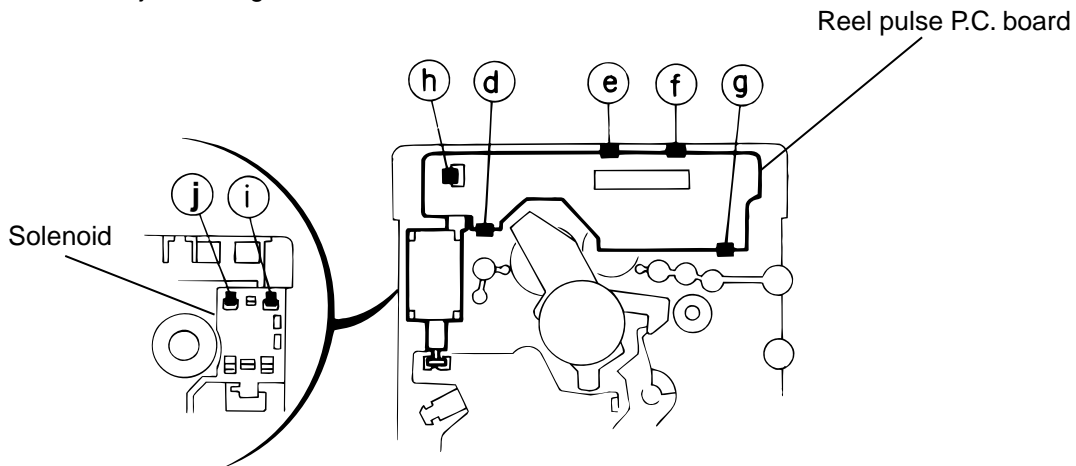

Fig. 9

Main adjustment

■ Measurement Instruments Required for Adjustment

1. Low frequency oscillator
This oscillator should have a capacity to output 0dBs to 600 Ω at an oscillation frequency of 50Hz-20kHz.
2. Attenuator impedance : 600 Ω
3. Electronic voltmeter
4. Distortion meter
5. Frequency counter
6. Wow & flutter meter
7. Test tape
VT703L : Head azimuth
VT712 : Tape speed and running unevenness (3kHz)
VT724 : Reference level (1kHz)
8. Blank tape
TYPE I : AC-225
TYPE II : AC-514
9. Torque gauge : For play and back tension
FWD(TW2111A), REV(TW2121a) and
FF/REW(TW2231A)
10. Test disc: CTS-1000

■ Measurement conditions

- Power supply voltage
: AC230V (50Hz)---B/E/EE/EN
: AC110/127V/230V(50/60Hz)
: UB/UF/US/UX/U
- Reference output : Speaker : 0.775V/4 Ω
: Headphone : 0.077V/32 Ω
- Reference frequency and
input level ----- 1kHz, AUX : -8dBs
MIX MIC: -54dBs (UB/UF/US/UX/U)
Input for confirming recording and playback
characteristics ----- AUX : -28dBs
Measurement output terminal ----- at Speaker J3002
※ Load resistance ----- 4 Ω

● Radio Input signal

- AM frequency ----- 400Hz
AM modulation ----- 30%
FM frequency ----- 400Hz
FM frequency deviation ----- 22.5kHz

● Tuner section

B/E/EN version

- FM Band cover: 87.5~108MHz
MW Band cover: 522~1,629kHz
LW Band cover: 144~288kHz

EE version

- FM Band cover: 65~74MHz, 87.5~108MHz
MW Band cover: 522~1,629kHz
LW Band cover: 144~288kHz

UB/UF/US/UX/U version

- FM Band cover: 87.5~108MHz
MW Band cover: 531~1,602kHz, 530~1,710kHz
SW Band cover: SW1 2.3~6.995MHz
: SW2 7~21.85MHz

Voltage applied to tuner ----- +B : DC5.7V
VT : DC 12V

Reference measurement

output ----- 26.1mV(0.28V)/3 Ω
Input positions ----- AM : Standard loop antenna
FM : TP1 (hot) and TP2 (GND)

● Standard measurement position of volume

Function switch ----- to Tape
Beat cut switch ----- to Cut
Super Bass/Active hyper Bass ----- to OFF
Bass Treble ----- to Center
Adjustment of main volume to reference output
VOL : 28

Precautions for measurement

1. Apply 30pF and 33k Ω to the IF sweeper output side and 0.082 μ F and 100k Ω in series to the sweeper input side.
2. The IF sweeper output level should be made as low as possible within the adjustable range.
3. Since the IF sweeper is a fixed device, there is no need to adjust this sweeper.
4. Since a ceramic oscillator is used, there is no need to perform any MIX adjustment.
5. Since a fixed coil is used, there is no need to adjust the FM tracking.
6. The input and output earth systems are separated. In case of simultaneously measuring the voltage in both of the input and output systems with an electronic voltmeter for two channels, therefore, the earth should be connected particularly carefully.
7. In the case of BTL connection amp., the minus terminal of speaker is not for earthing. Therefore, be sure not to connect any other earth terminal to this terminal. This system is of an BTL system.
8. For connecting a dummy resistor when measuring the output, use the wire with a greater code size.
9. Whenever any mixed tape is used, use the band pass filter (DV-12).

<<Arrangement of Adjusting Position>>

Cassette mechanism section

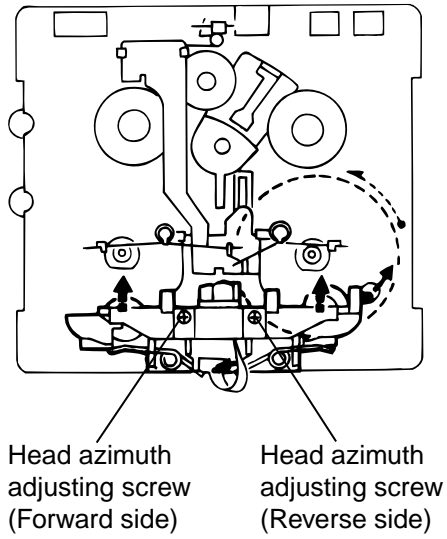

Cassette mechanism section (Back side)

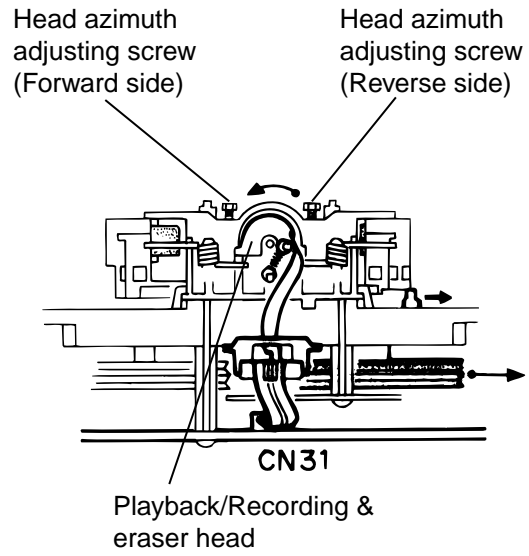

Front panel assembly section

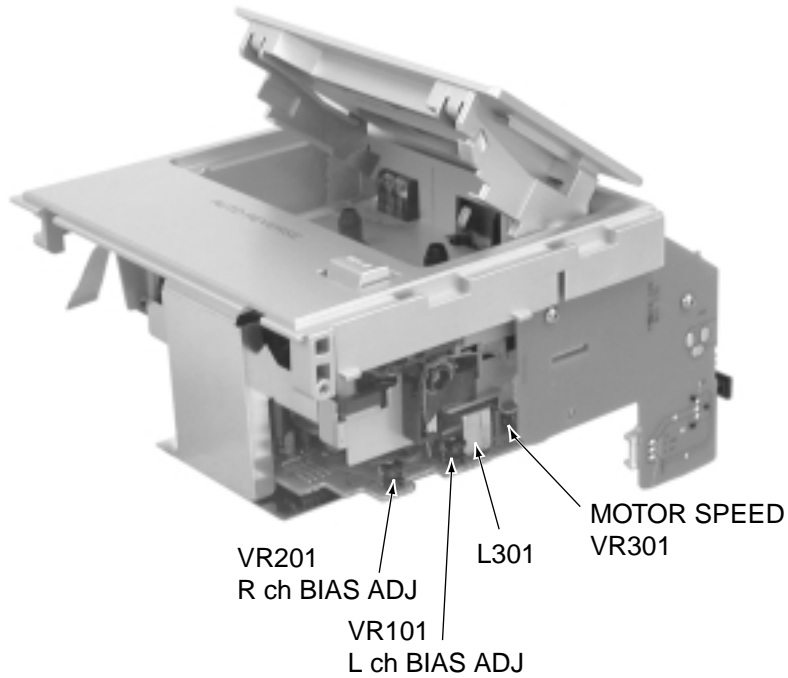

■ Tape Recorder Section

Items	Measurement conditions	Measurement method	Standard Values	Adjusting positions
Confirmation of head angle	Test tape : VTT703L (8kHz) Measurement output terminal : Speaker terminal Speaker R (Load resistance: 4Ω) : Headphone terminal	1 Playback the test tape VTT703L (8kHz) 2 With the recording & playback mechanism, adjust the head azimuth screw so that the forward and reverse output levels become maximum. After adjustment, lock the head azimuth at least by half turn. 3 In either case, this adjustment should be performed in both the forward and reverse directions with the head azimuth screw.	Maximum output	Adjust the head azimuth screw only when the head has been changed.
Confirmation of tape speed	Test tape : VT712 (3kHz) Measurement output terminal : Headphone terminal	Adjust VR37 so that the frequency counter reading becomes 2,940~3,090Hz \pm when playing back the test tape VT712 (3kHz) with playback and recording mechanism after ending forward winding of the tape.	Tape speed of deck : 2,940 ~ 3,090Hz	VR301

■ Reference Values for Confirmation Items

Items	Measurement conditions	Measurement method	Standard Values	Adjusting positions
Difference between the forward and reverse speed	Test tape : VT712 (3kHz) Measurement output terminal : Speaker terminal Speaker R (Load resistance: 4Ω) Measurement output terminal : Headphone	When the test tape VT712 (3kHz) has been played back with the recording and playback mechanism at the beginning of forward winding, the frequency counter reading of the difference between both of the mechanism should be 6.0Hz or less.	6.0Hz or less	Head azimuth screw
Wow & flutter	Test tape : VT712 (3kHz) Measurement output terminal : Headphone terminal	When the test tape VT712 (3kHz) has been played back with the recording and playback mechanism at the beginning of forward winding, the frequency counter reading of wow & flutter should be 0.25% or less (WRMS).	0.25% or less (WRMS)	

■ Electrical Performance

Items	Measurement conditions	Measurement method	Standard Values	Adjusting positions
Adjustment of recording bias current (Reference Value)	<ul style="list-style-type: none"> • Mode: Forward or reverse mode • Recording mode • Test tape : AC-514 to TYPE II and AC-225 to TYPE I Measurement output terminal : Both recording and headphone terminals	<ol style="list-style-type: none"> 1 With the recording and playback mechanism, load the test tapes (AC-514 to TYPE II and AC-225 to TYPE I), and set the mechanism to the recording and pausing condition in advance. 2 After connecting 100 Ω in series to the recorder head, measure the bias current with a valve voltmeter at both of the terminals. 3 After resetting the [PAUSE] mode, start recording. At this time, adjust VR31 for Lch and VR32 for Rch so that the recording bias current values become 4.0 μ A (TYPE I) and 4.20 μ A (TYPE II). 	AC-225 : 4.20 μ A AC-514 : 4.0 μ A	L ch : VR101 R ch : VR201
Adjustment of recording and playback frequency characteristics	Reference frequency : 1kHz and 10kHz (REF.: -20dB) Test tape : AC-514 to TYPE II Measurement input terminal : OSC IN	<ol style="list-style-type: none"> 1 With the recording and playback mechanism, load the test tapes (AC-514 to TYPE II), and set the mechanism to the recording and pausing condition in advance. 2 While repetitively inputting the reference frequency signal of 1kHz and 10kHz from OSC IN, record and playback the tape. 3 While recording and playback the test tape in TYPE II, adjust VR31 for Lch and VR32 for Rch so that the output deviation between 1kHz and 10kHz becomes -1dB \pm 2dB. 	Output deviation between 1kHz and 10kHz : -1dB \pm 2dB	L ch : VR101 R ch : VR201

■ Reference Values for Electrical Function Confirmation Items

Items	Measurement conditions	Measurement method	Standard Values	Adjusting positions
Recording bias frequency	Forward or reverse <ul style="list-style-type: none"> • Test tape : TYPE II (AC-514) • Measurement terminal : BIAS TP on P.C. board 	<ol style="list-style-type: none"> 1 While changing over to and from BIAS 1 and 2, confirm that the frequency is changed. 2 With the recording and playback mechanism, load the test tape. (AC-514 to TYPE II), and set the mechanism to the recording and pausing condition in advance. 3 Confirm that the BIAS TP frequency on the P.C. board is 100kHz \pm 6kHz. 	100 kHz \pm 6 kHz	
Eraser current (Reference value)	Forward or reverse <ul style="list-style-type: none"> • Recording mode • Test tape : AC-514 to TYPE II and AC-225 to TYPE I Measurement terminal : Both of the eraser head terminals	<ol style="list-style-type: none"> 1 While recording and playback mechanism, load the test tapes (AC-514 to TYPE II and AC-225 to TYPE I), and set the mechanism to the recording and pausing conditions in advance. 2 After setting to the recording conditions, connect 1W in series to the eraser head on the recording and playback mechanism side, and measure the eraser current from both of the eraser terminals. 	TYPE II : 120 mA TYPE I : 75 mA	

Flow of functional operation until TOC read

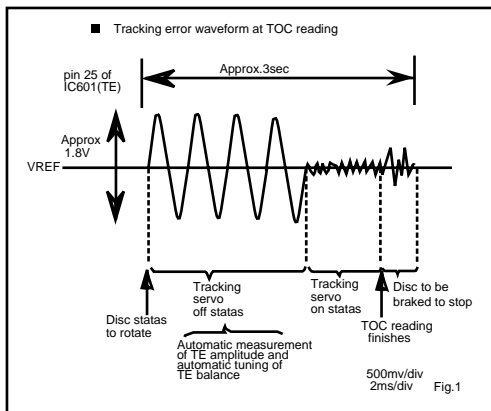
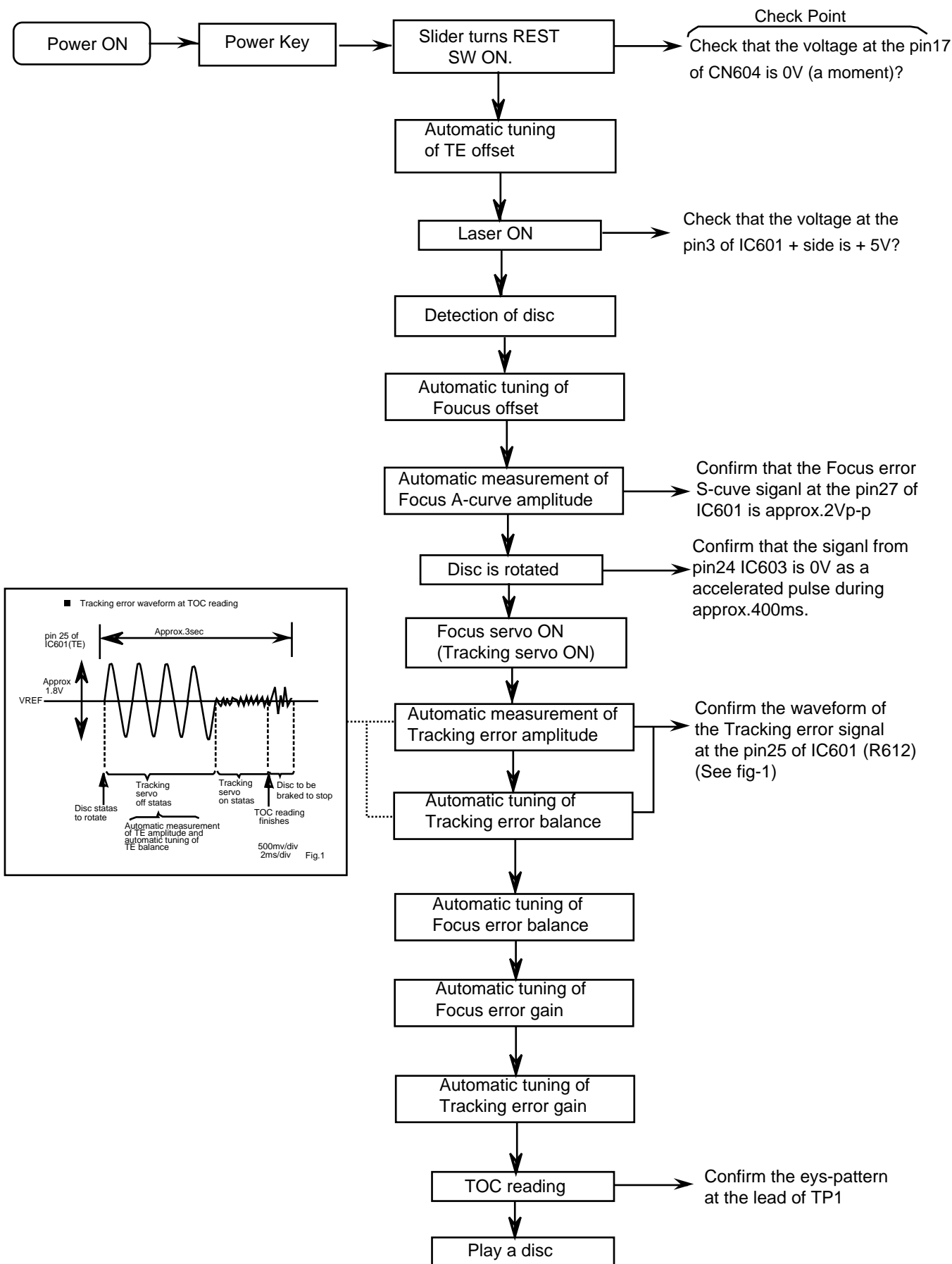

Maintenance of laser pickup

(1) Cleaning the pick up lens

Before you replace the pick up, please try to clean the lens with a alcohol soaked cotton swab.

(2) Life of the laser diode (Fig.1)

When the life of the laser diode has expired, the following symptoms will appear.

- (1) The level of RF output (EFM output: amplitude of eye pattern) will below.

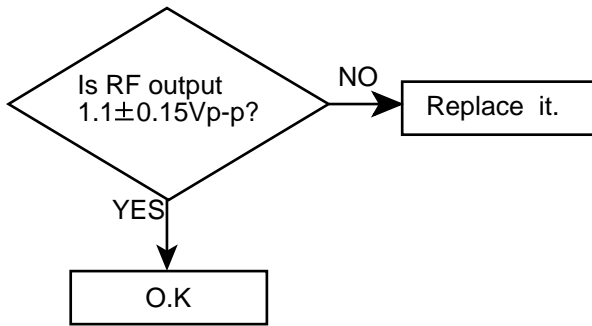

(Fig.1)

(3) Semi-fixed resistor on the APC PC board

The semi-fixed resistor on the APC printed circuit board which is attached to the pickup is used to adjust the laser power. Since this adjustment should be performed to match the characteristics of the whole optical block, do not touch the semi-fixed resistor.

If the laser power is lower than the specified value, the laser diode is almost worn out, and the laser pickup should be replaced.

If the semi-fixed resistor is adjusted while the pickup is functioning normally, the laser pickup may be damaged due to excessive current.

Replacement of laser pickup

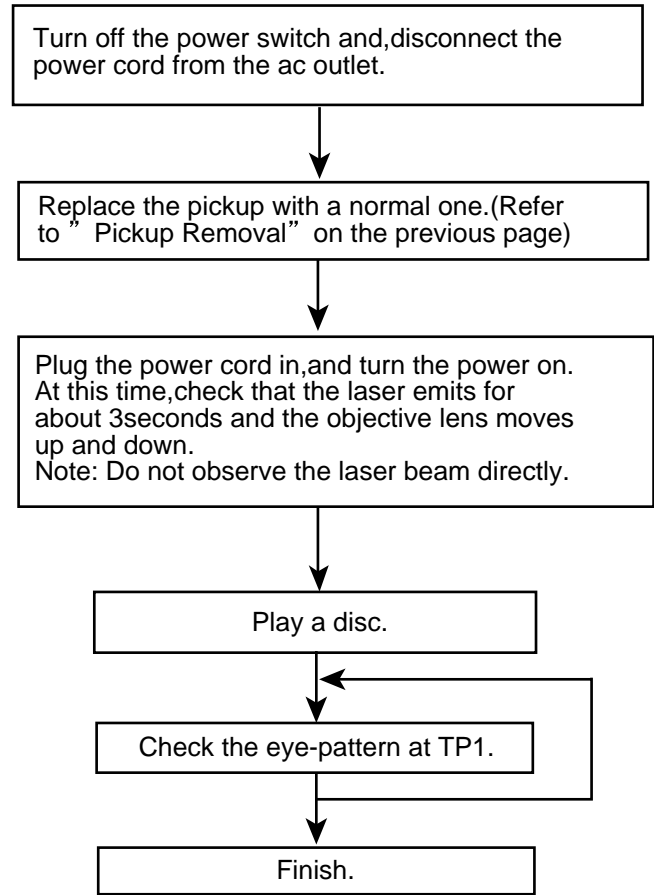

Description of major ICs

■ LA6541-X(IC541) : Servo Driver

1. Pin Layout & Block Diagram

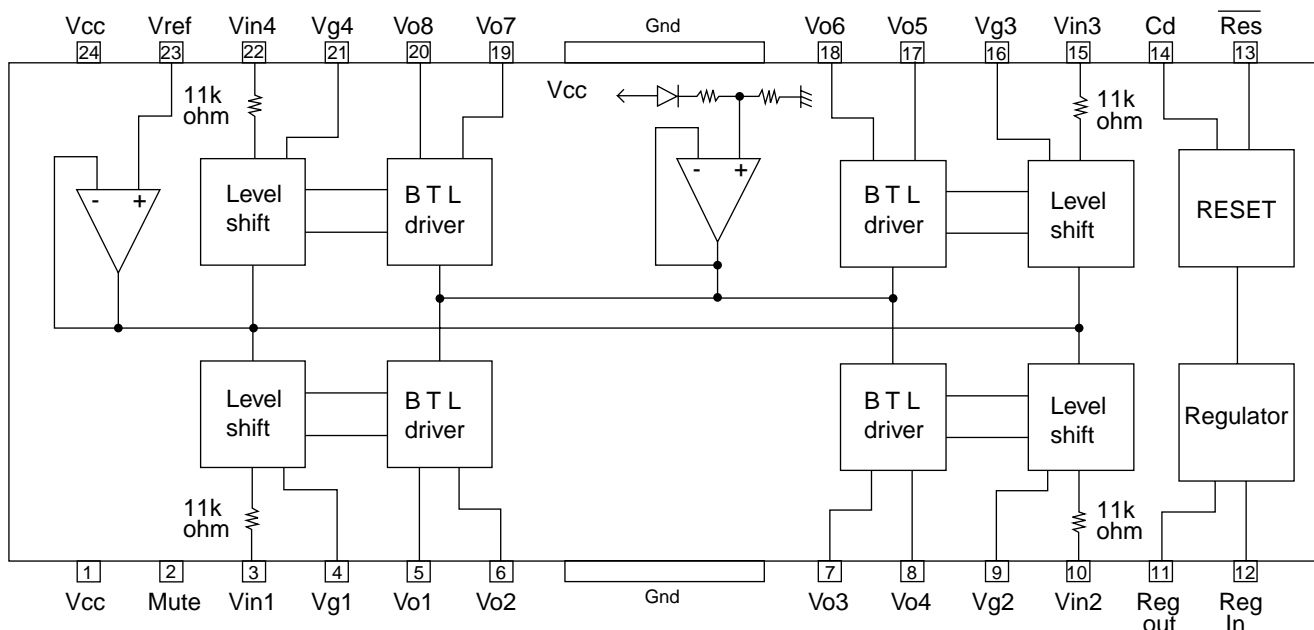

2. Pin functions

Pin No.	Symbol	Function
1	Vcc	Power supply (Shorted to pin 24)
2	Mute	All BTL amplifier outputs ON/OFF
3	Vin1	BTL AMP 1 input pin
4	Vg1	BTL AMP 1 input pin (For gain adjustment)
5	Vo1	BTL AMP 1 input pin (Non inverting side)
6	Vo2	BTL AMP 1 input pin (Inverting side)
7	Vo3	BTL AMP 2 input pin (Inverting side)
8	Vo4	BTL AMP 2 input pin (Non inverting side)
9	Vg2	BTL AMP 2 input pin (For gain adjustment)
10	Vin2	BTL AMP 2 input pin
11	Reg Out	External transistor collector (PNP) connection. 5V power supply output
12	Reg In	External transistor (PNP) base connection
13	Res	Reset output
14	Cd	Reset output delay time setting (Capacitor connected externally)
15	Vin3	BTL AMP 3 input pin
16	Vg3	BTL AMP 3 input pin (For gain adjustment)
17	Vo5	BTL AMP 3 output pin (Non inverting side)
18	Vo6	BTL AMP 3 output pin (Inverting side)
19	Vo7	BTL AMP 4 output pin (Inverting side)
20	Vo8	BTL AMP 4 output pin (Non inverting side)
21	Vg4	BTL AMP 4 output pin (For gain adjustment)
22	Vin4	BTL AMP 4 output pin
23	Vref	Level shift circuit's reference voltage application
24	Vcc	Power supply (Shorted to pin 1)

■ MN35510 (IC651) : DIGITAL SERVO&DIGITAL SIGNAL PROCESSER

1. Terminal Layout

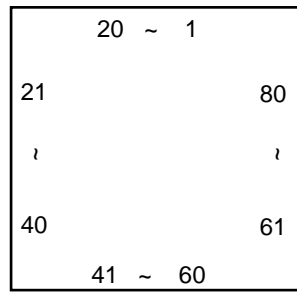

2. Block Diagram

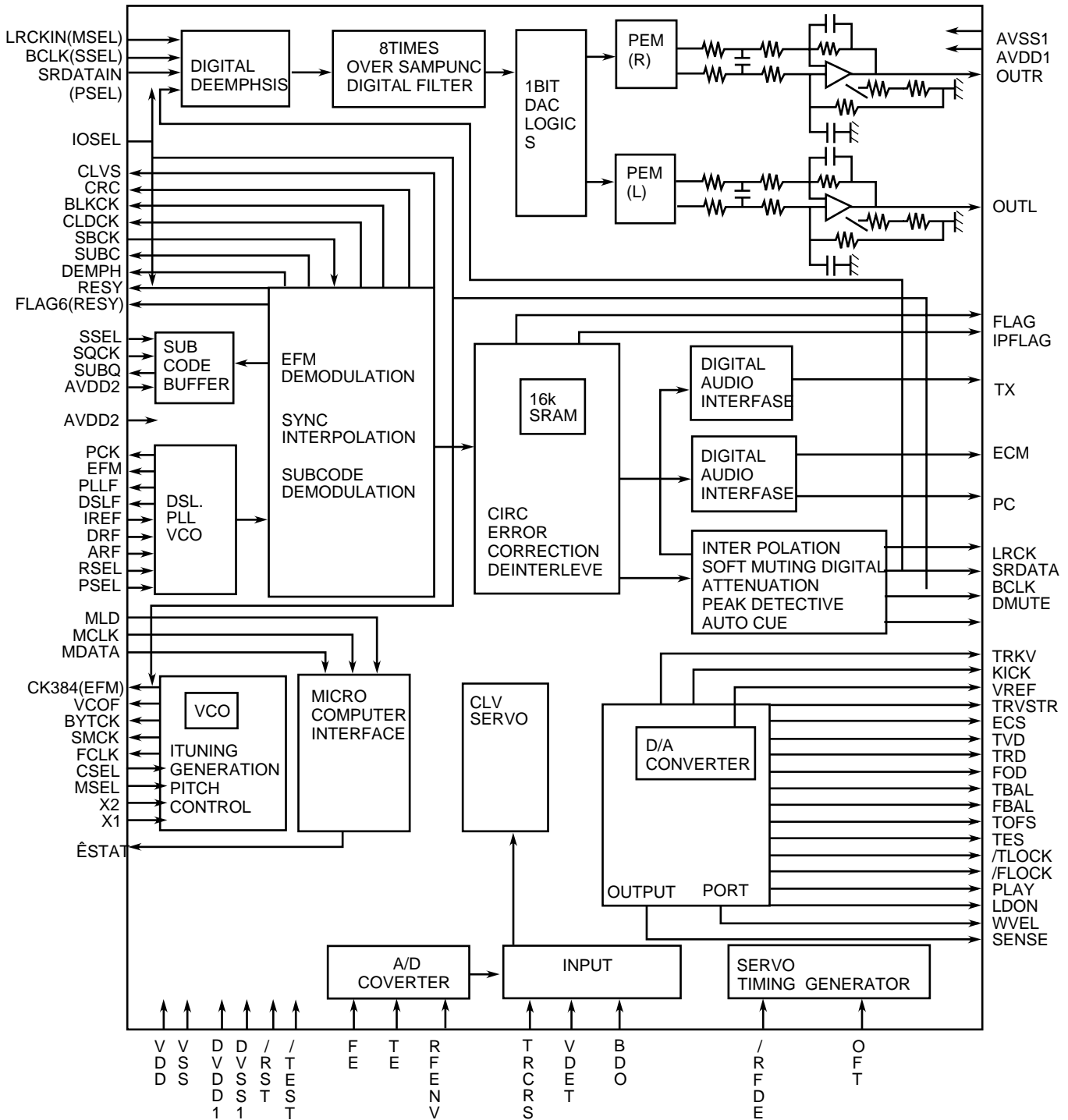

3. Description

Pin No.	symbol	I/O	Description	Pin No.	symbol	I/O	Description
1	BCLK	O	Not used	41	TES	O	Tracking error shunt signal output(H:shunt)
2	LRCK	O	Not used	42	PLAY	—	Not used
3	SRDATA	O	Not used	43	WVEL	—	Not used
4	DVDD1	—	Power supply (Digital)	44	ARF	I	RF signal input
5	DVSS1	—	Connected to GND	45	IREF	I	Reference current input pin
6	TX	O	Digital audio interface output	46	DRF	I	Bias pin for DSL
7	MCLK	I	μ com command clock signal input (Data is latched at signal's rising point)	47	DSL F	I/O	Loop filter pin for DSL
8	MDATA	I	μ com command data input	48	PLL F	I/O	Loop filter pin for PLL
9	MLD	I	μ com command load signal input	49	VCOF	—	Not used
10	SENSE	O	Sence signal output	50	AVDD2	—	Power supply(Analog)
11	FLOCK	O	Focus lock signal output Active :Low	51	AVSS2	—	Connected to GND(Analog)
12	TLOCK	O	Tracking lock signal output Active :Low	52	EFM	—	Not used
13	BLKCK	O	sub-code·block·clock signal output	53	PCK	—	Not used
14	SQCK	I	Outside clock for sub-code Q resistor input	54	PDO	—	Not used
15	SUBQ	O	Sub-code Q -code output	55	SUBC	—	Not used
16	DMUTE	—	Connected to GND	56	SBCK	—	Not used
17	STATUS	O	Status signal (CRC,CUE,CLVS,TTSTOP,ECLV,SQOK)	57	VSS	—	Connected to GND(for X'tal oscillation circuit)
18	RST	I	Reset signal input (L:Reset)	58	XI	I	Input of 16.9344MHz X'tal oscillation circuit
19	SMCK	—	Not used	59	X2	O	Output of X'tal oscillation circuit
20	PMCK	—	Not used	60	VDD	—	Power supply(for X'tal cscillation circuit)
21	TRV	O	Traverse enforced output	61	BYTCK	—	Not used
22	TVD	O	Traverse drive output	62	CLDCK	—	Not used
23	PC	—	Not used	63	FLAG	—	Not used
24	ECM	O	Spindle motor drive signal (Enforced mode output) 3-State	64	IPPLAG	—	Not used
25	ECS	O	Spindle motor drive signal (Servo error signal output)	65	FLAG	—	Not used
26	KICK	O	Kick pulse output	66	CLVS	—	Not used
27	TRD	O	Tracking drive output	67	CRC	—	Not used
28	FOD	O	Focus drive output	68	DEMPH	—	Not used
29	VREF	I	Reference voltage input pin for D/A output block (TVD,FOD,FBA,TBAL)	69	RESY	—	Not used
30	FBAL	O	Focus Balance adjust signal output	70	IOSEL	—	pull up
31	TBAL	O	Tracking Balance adjust signal output	71	TEST	—	pull up
32	FE	I	Focus error signal input(Analog input)	72	AVDD1	—	Power supply(Digital)
33	TE	I	Tracking error signal input(Analog input)	73	OUT L	O	Lch audio output
34	RF ENV	I	RF envelope signal input(Analog input)	74	AVSS1	—	Connected to GND
35	VDET	I	Vibration detect signal input(H:detect)	75	OUT R	O	Rch audio output
36	OFT	I	Off track signal input(H:off track)	76	RSEL	—	pull up
37	TRCRS	I	Track cross signal input	77	CSEL	—	Connected to GND
38	RFDET	I	RF detect signal input(L:detect)	78	PSEL	—	Connected to GND
39	BDO	I	BDO input pin(L:detect)	79	MSEL	—	Connected to GND
40	LDON	O	Laser ON signal output(H:on)	80	SSEL	—	Pull up

■AN8806SB-W(IC301) :RF&SERVO AMP

1.Pin layout

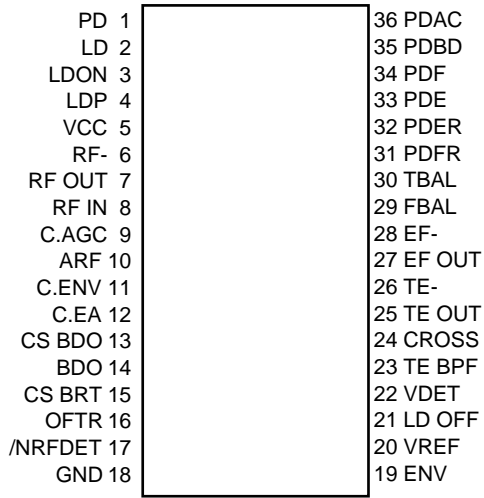

2.Block diagram

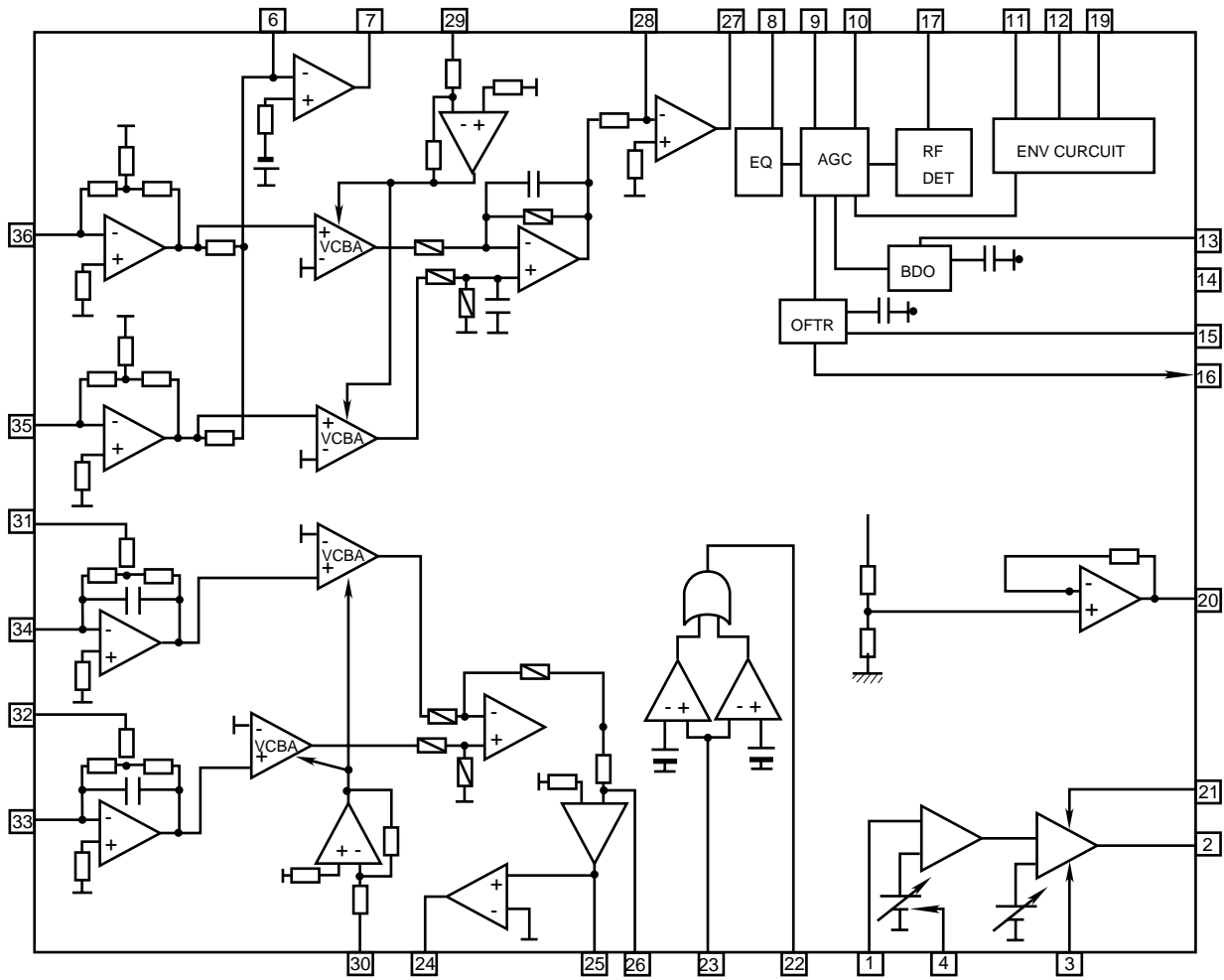

3. Pin function

Pin No.	symbol	I/O	Function
1	PD	I	APC amp . Input terminal
2	LD	O	APC amp . Output terminal
3	LD ON	I	LD ON/OFF control terminal
4	LDP	--	Connect to GND
5	VCC	--	Power supply
6	RF-	I	RF amp . Reversing input terminal
7	RF OUT	O	RFamp . Output terminal
8	RF IN	I	AGC input terminal
9	C.AGC	I/O	AGC loop filter connection terminal
10	ARF	O	ARF output terminal
11	C.ENV	I/O	RF detection capacity connection terminal
12	C.EA	I/O	HPF-amp capacity connection terminal
13	CS BDO	I/O	Capacity connection terminal for RF discernment side envelope detection
14	BDO	O	BDO output terminal
15	CS BRT	I/O	Capacity connection terminal for RF discernment side envelope detection
16	OFTR	O	OFTR output terminal
17	/NRFDET	O	RFDET output terminal
18	GND	--	Connect to GND
19	ENV	O	3TENV output terminal
20	VREF	O	VREF output terminal
21	LD OFF	--	APC OFF control terminal
22	VDET	O	VDET output terminal
23	TE BPF	I	VDET input terminal
24	CROSS	O	CROSS output terminal
25	TE OUT	O	TE amp . Output terminal
26	TE-	I	FE amp . Reversing input terminal
27	FE OUT	O	FE amp . output terminal
28	FE-	I	FE amp . Reversing input terminal
29	FBAL	I	F.BAL control terminal
30	TBAL	I	T.BAL control terminal
31	PDFR	I/O	I-V amp conversion resistance adjustment terminal
32	PDER	I/O	I-V amp conversion resistance adjustment terminal
33	PDF	I	I-V amp input terminal
34	PDE	I	I-V amp input terminal
35	PD BD	I	I-V amp input terminal
36	PD AC	I	I-V amp input terminal

■ UPD78064GF-108 (IC701): System CPU

1. Pin layout

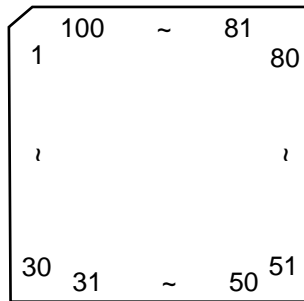

2. Pin function

Pin No.	Symbol	I/O	Function	Pin No.	Symbol	I/O	Function
1	USDATA	I/O	Serial data	29	URESET/CLOSE	I	[RESET/CLOSE] switch
2	USCK	O	Serial clock	30	USAFETY1	I	Abnormal voltage detection 1
3	UQRIN	I	CD Q code data	31	USAFETY0	I	Abnormal voltage detection 2
4	UNC	-	Non connect	32	UKEY1	I	Body key input 1
5	USQCK	O	CD Q code data synchronizing clock	33	UKEY0	I	Body key input 0
6	ICVSS	-	Connected to VSS	34	UTAPE0	I	Tape switch 0
7	UX2	-	Main system clock	35	UTAPE1	I	Tape switch 1
8	UX1	I	Main system clock	36	AVDD	-	AD converter power supply
9	VDD	-	Power supply	37	UAVREF	-	AD converter reference voltage
10	UXT1	I	Sub system clock	38	UBUP	I	Backup power supply decision
11	UXT2	-	Sub system clock	39	UFTUNER	O	Function tuner
12	URESET	I	Reset	40	VSS	-	GND
13	UREM	I	Remote control	41	UMPX	I	FM stereo detection
14	URDSCK	-	Non connect	42	UPERIOD	O	Tuner PLL strobe
15	UJOG1	I	Jog encoder 1	43	UJOGB	I	JOG encoder 2
16	UBEAT2	O	Main clock selection 2	44	UBASS	O	BASS control
17	UBEAT1	O	Main clock selection 1	45	UTRE	O	TRE control
18	U+BCTL	O	Switched 5V control	46	UVOL	O	VOL.control
19	UXRESET	O	CD LSI reset	47	USBASS	O	AHB on/off
20	UMCLK	O	CD LSI command clock	48	USMUTE	O	System muting
21	UMDATA	O	CD LSI command data	49	UPOUT	O	Power ON/OFF
22	UMLD	O	CD LSI command load	50	UFCD	O	Function CD
23	UPBMUTE	O	Tape playback mute	51~54	COM0~3	O	LCD common
24	ULATCH	O	Tape IC strobe	55	BIAS	-	LCD bias voltage
25	UREEL	I	Tape end detection	56~58	VLC0~2	-	LCD bias voltage
26	UFAUX	O	Function AUX	59	VSS	-	GND
27	UAVSS	-	AD converter GND	60~99	S0~39	O	LCD segment
28	USAFEYCD	I	CD abnormal voltage detection	100	USTATUS	I	LCD LSI status

■ LA1838(IC102): FM AM IF AMP&detector, FM MPX Decoder

1. Block Diagram

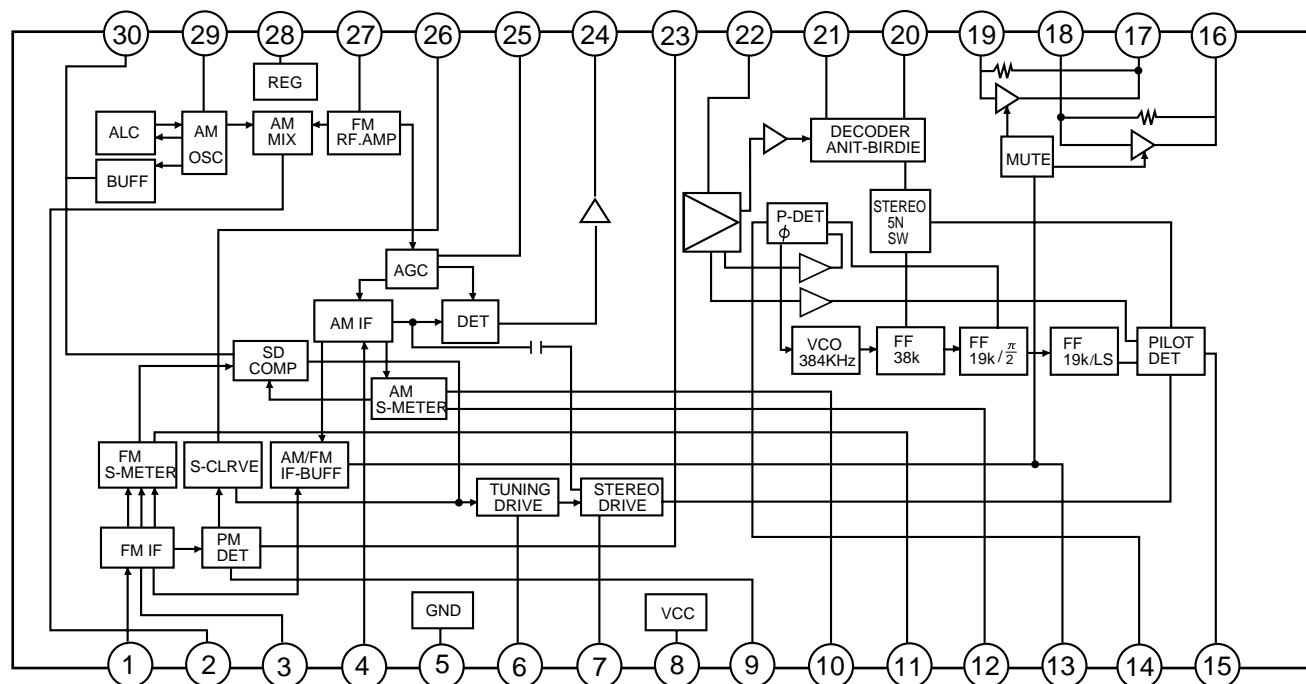

2. Pin Function

Pin No.	Symbol	I/O	Function	Pin No.	Symbol	I/O	Function
1	FM IN	I	This is an input terminal of FM IF signal.	16	R OUT	O	Right channel signal output.
2	AM MIX	O	This is an out put terminal for AM mixer.	17	L OUT	O	Left channel signal output.
3	FM IF	I	Bypass of FM IF	18	R IN	I	Input terminal of the Right channel post AMP.
4	AM IF	I	Input of AM IF Signal.	19	L IN	I	Input terminal of the Left channel post AMP.
5	GND	-	This is the device ground terminal.	20	RO	O	Mpx Right channel signal output.
6	TUNED	O	When the set is tuning, this terminal becomes "L".	21	LO	O	Mpx Left channel signal output.
7	STEREO	O	Stereo indicator output. Stereo "L", Mono: "H"	22	IF IN	I	Mpx input terminal
8	VCC	-	This is the power supply terminal.	23	FM OUT	O	FM detection output.
9	FM DET	-	FM detect transformer.	24	AM DET	O	AM detection output.
10	AM SD	-	This is a terminal of AM ceramic filter.	25	AM AGC	I	This is an AGC voltage input terminal for AM
11	FM VSM	O	Adjust FM SD sensitivity.	26	AFC	-	This is an output terminal of voltage for FM-AFC.
12	AM VSM	O	Adjust AM SD sensitivity.	27	AM RF	I	AM RF signal input.
13	MUTE	I/O	When the signal of IF REQ of IC121(LC72131) appear, the signal of FM/AM IF output. //Muting control input.	28	REG	O	Register value between pin 26 and pin28 besides the frequency width of the input signal.
14	FM/AM	I	Change over the FM/AM input. "H" :FM, "L" : AM	29	AM OSC	-	This is a terminal of AM Local oscillation circuit.
15	MONO/ST	O	Stereo : "H", Mono: "L"	30	OSC BUFFER	O	AM Local oscillation Signal output.

■ LC72136N (IC121) : PLL Frequency Synthesizer

1. Pin layout

XT	1	22	XT
FM/AM	2	21	GND
CE	3	20	LPFOUT
DI	4	19	LPFIN
CLOCK	5	18	PD
DO	6	17	VCC
FM/ST/VCO	7	16	FMIN
AM/FM	8	15	AMIN
	9	14	
	10	13	IFCONT
SDIN	11	12	IFIN

2. Block diagram

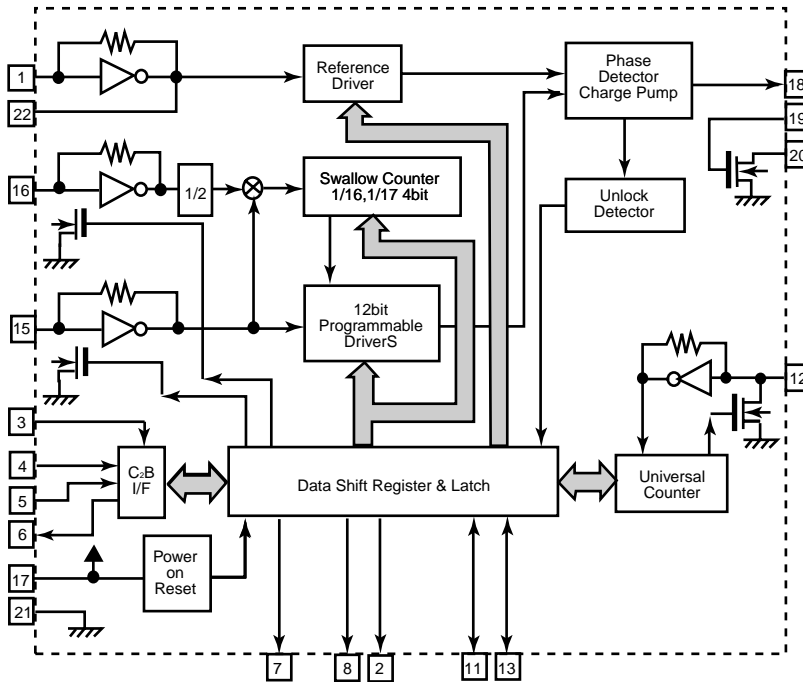

3. Pin function

Pin No.	Symbol	I/O	Function	Pin No.	Symbol	I/O	Function
1	XT	I	X'tal oscillator connect (75kHz)	12	IFIN	I	IF counter signal input
2	FM/AM	O	LOW:FM mode	13	IFCONT	O	IF signal output
3	CE	I	When data output/input for 4pin(input) and 6pin(output): H	14		-	Not use
4	DI	I	Input for receive the serial data from controller	15	AMIN	I	AM Local OSC signal output
5	CLOCK	I	Sync signal input use	16	FMIN	I	FM Local OSC signal input
6	DO	O	Data output for Controller Output port	17	VCC	-	Power supply(VDD=4.5-5.5V) When power ON:Reset circuit move
7	FM/ST/VCO	O	"Low": MW mode	18	PD	O	PLL charge pump output(H: Local OSC frequency Height than Reference frequency. L: Low Agreement: Height impedance)
8	AM/FM	O	Open state after the power on reset	19	LPFIN	I	Input for active lowpassfilter of PLL
9	LW	I/O	Input/output port	20	LPFOUT	O	Output for active lowpassfilter of PLL
10	MW	I/O	Input/output port	21	GND	-	Connected to GND
11	SDIN	I/O	Data input/output	22	XT	I	X'tal oscillator(75KHz)

■ **BA15218N (IC342/IC343/IC391/IC453/IC362/IC363)**
: Dual Ope. Amp.

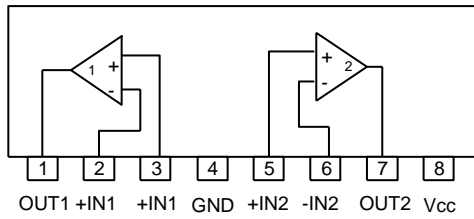

■ **BU4094BCF-X(IC304,IC303):Serial to parallel port extension**

1.Pin layout

STROBE	1	16	Vdd
DATA	2	15	OUTPUT ENABLE
CLOCK	3	14	Q5
Q1	4	13	Q6
Q2	5	12	Q7
Q3	6	11	Q8
Q4	7	10	Q's
Vss	8	9	Qs

2.Block diagram

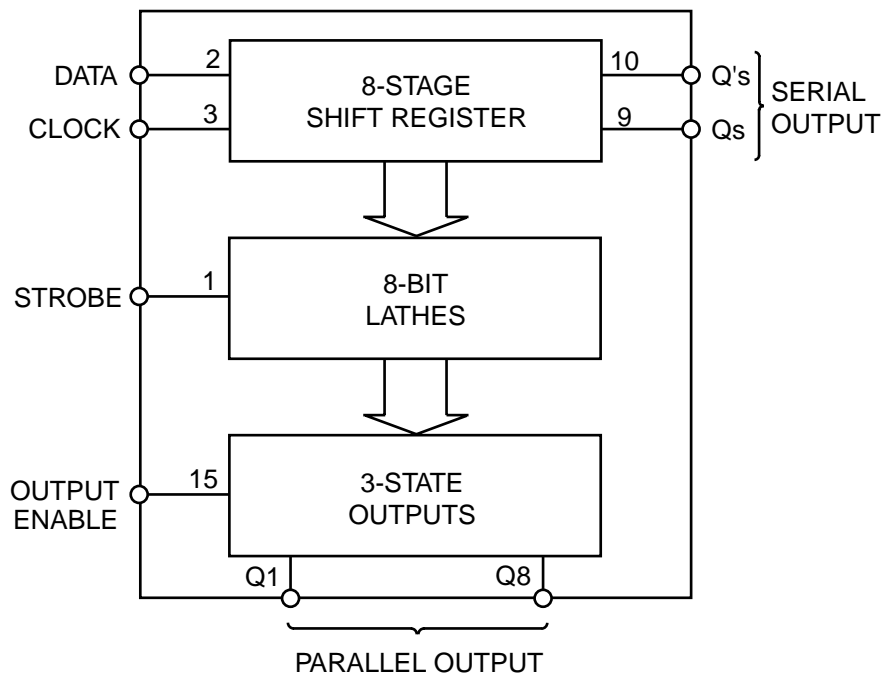

■ GP1U271X (IC701) : Receiver for remote

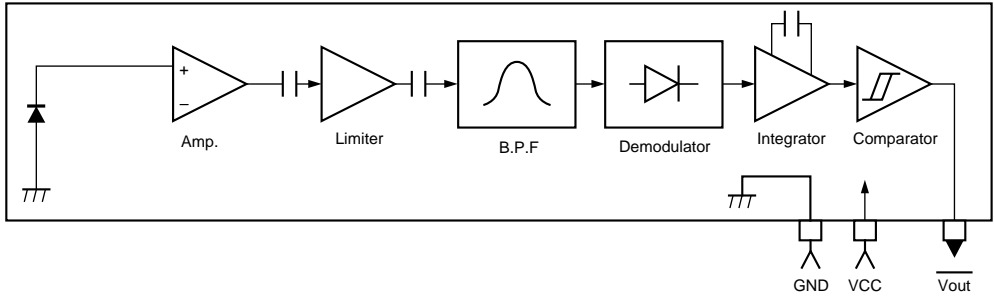

■ LB1641 (IC501) : DC Motor Driver

1. Pin Layout

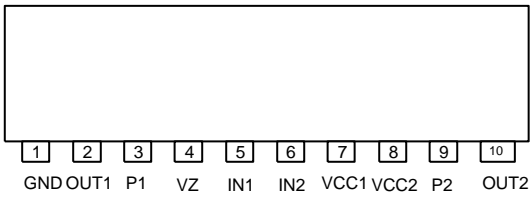

2. Pin Functions

Input		Output		Mode
IN1	IN2	OUT1	OUT2	
0	0	0	0	Brake
1	0	1	0	CLOCKWISE
0	1	0	1	COUNTER-CLOCKWISE
1	1	0	0	Brake

■ AN7345(IC302) PB/REC AMP

1. Block diagram

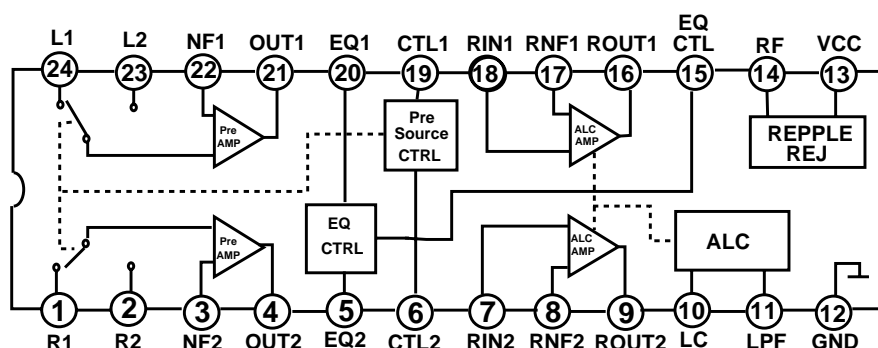

2. Pin Function

Pin No.	Symbol	I/O	Function	Pin No.	Symbol	I/O	Function
1	R1	I	Playback amplifier input	13	Vcc	I	Power supply
2	R2	I	Playback amplifier input	14	RF	I	Repple filter
3	NF2	I	Playback amplifier negative feedback	15	EQCTL	I	EQ control
4	OUT2	O	Playback amplifier output	16	ROUT 1	O	Recording amplifier output
5	EQ2	I	Equalaizer	17	RNF1	I	Recording amplifier negative feedback
6	CTL2	I	Pre Amplifier input swithing time constant	18	RIN1	I	Recording amplifier input
7	RIN2	I	Recording amplifier input	19	CTL1	I	Pre amplifier input swithing control
8	RNF2	I	Recording amplifier negative feedback	20	EQ1	I	Equalayzer
9	ROUT2	O	Recording amplifier output	21	OUT1	O	Playback amplifier output
10	LC	I	ALC low cut	22	NF1	I	Playback amplifier negative feedback
11	LPF	I	ALC low pass filter	23	L2	I	Playback amplifier input
12	GND	I	—	24	L1	I	Playback amplifier input

LC75342

1. Pin assignment

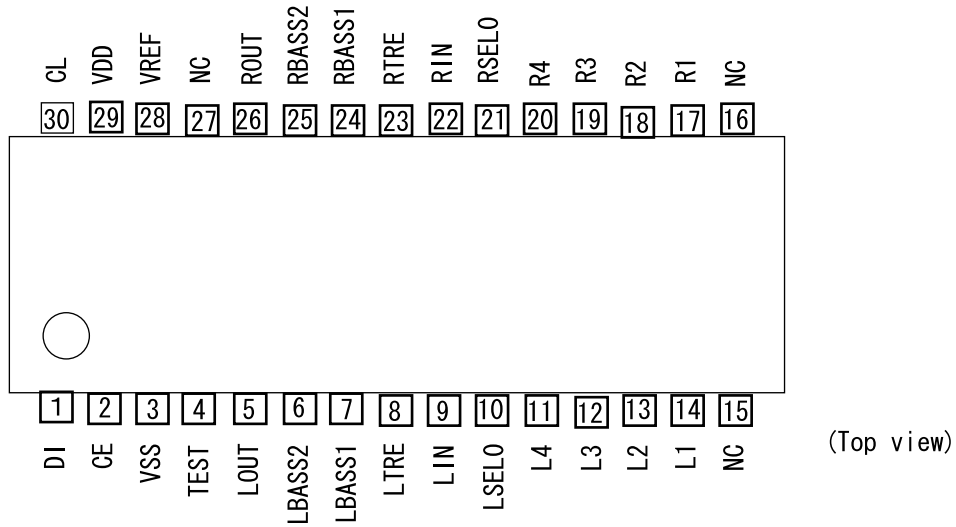

2. Block

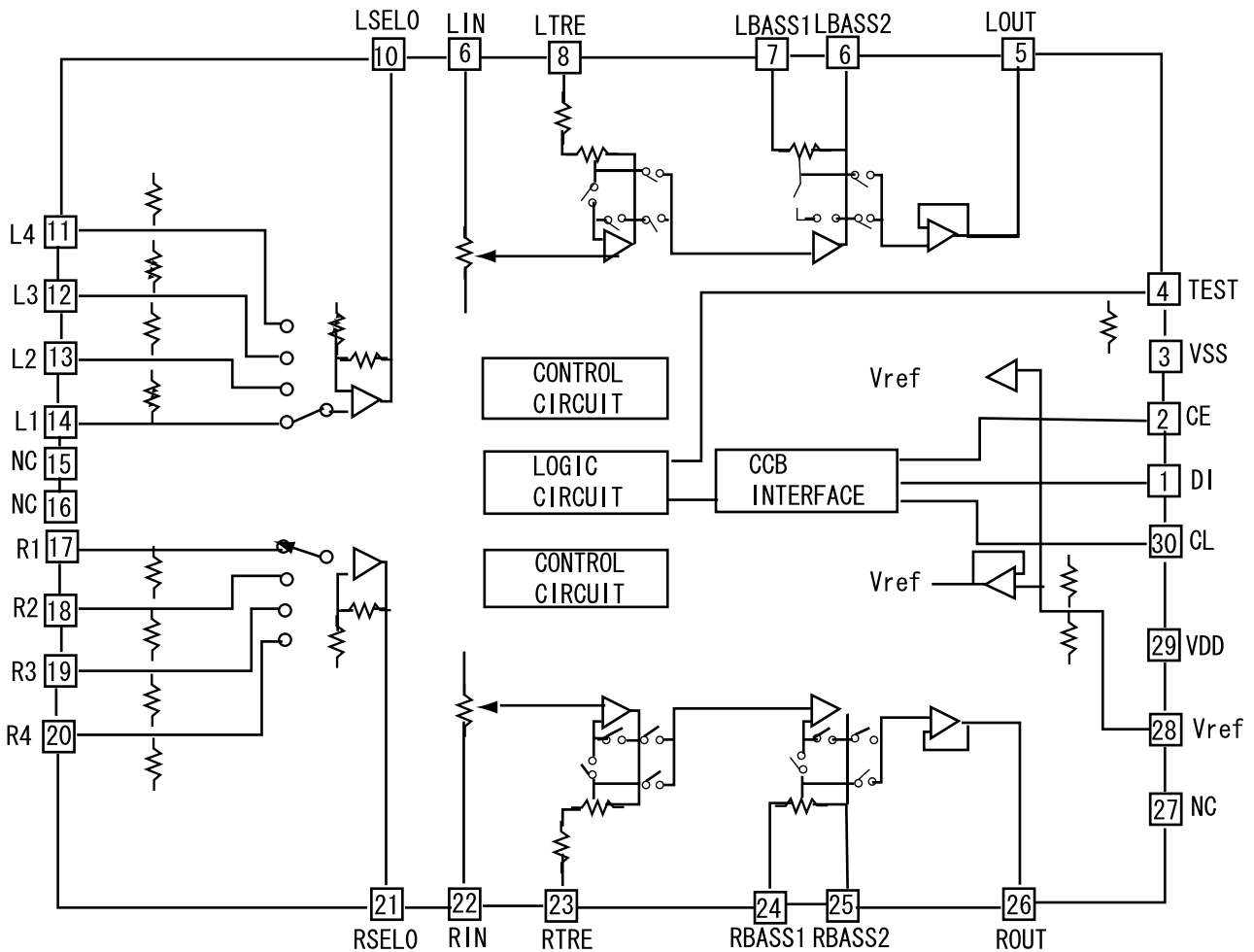

3. Pin function

Pin No.	symbol	I/O	Function
1	D1	I	Serial data input pin for control
2	CE	I	Chip enable pin
3	Vss	--	Ground
4	TEST	I	TEST pin for electronic volume control
5	LOUT	O	Volume+equalizer output
6	LBASS2	O	Bas-band filter comprising capacitor and resistor connection
7	LBASS1	I	Bas-band filter comprising capacitor and resistor connection
8	LTRE	I	Capacitor connection pin comprising treble band filter
9	LIN	I	Volume+equalizer input
10	LSEL0	O	Input selector output pin
11	L4	I	Input signal pin
12	L3	I	Input signal pin
13	L2	I	Input signal pin
14	L1	I	Input signal pin
15	NC	--	No connect
16	NC	--	No connect
17	R1	I	Input signal pin
18	R2	I	Input signal pin
19	R3	I	Input signal pin
20	R4	I	Input signal pin
21	RSEL0	O	Input selector output pin
22	RIN	I	Volume+equalizer input
23	RTRE	I	Capacitor connection pin comprising treble band filter
24	RBASS1	I	Bas-band filter comprising capacitor and resistor connection
25	RBASS2	O	Bas-band filter comprising capacitor and resistor connection
26	ROUT	O	Volume+equalizer output
27	NC	--	No connect
28	Vref	O	Analog ground
29	VDD	I	Power Supply
30	CL	I	Clock input

■ LC72723

1. Pin Assignment

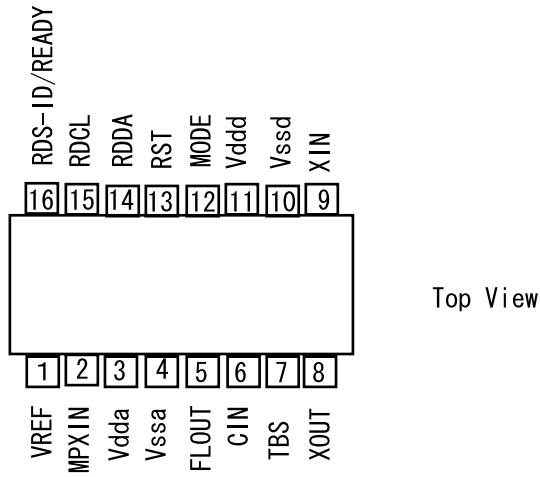

2. Block diagram

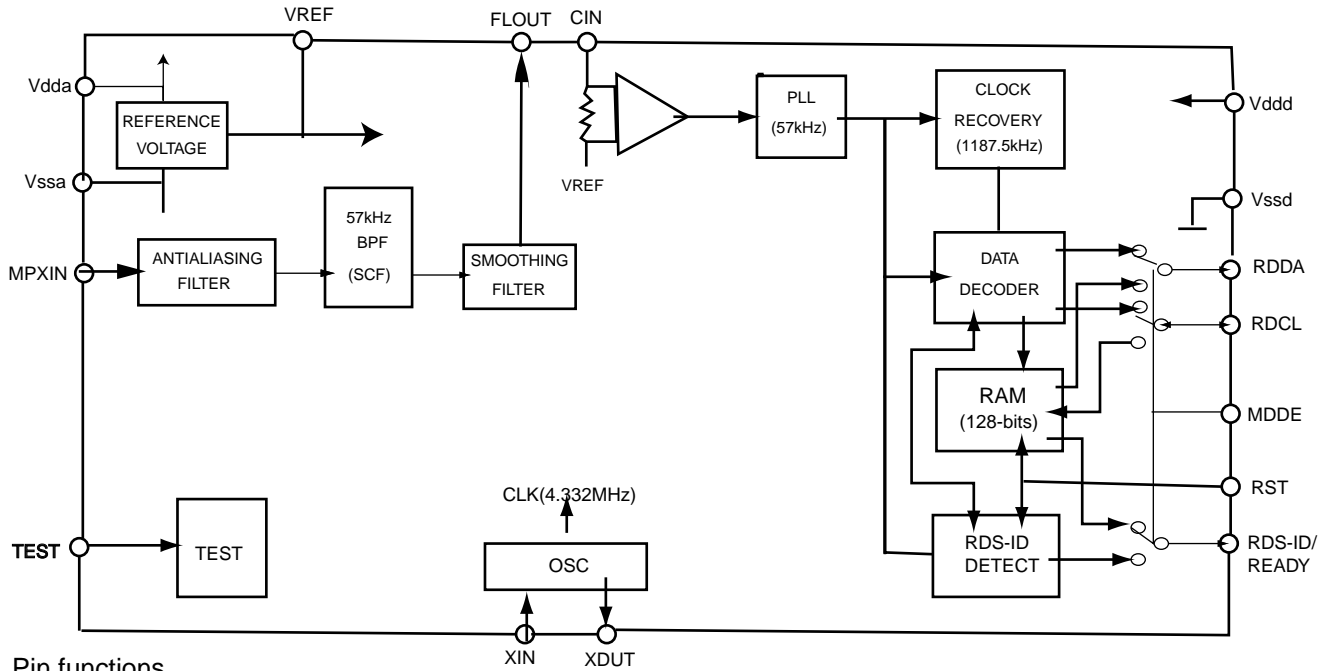

3. Pin functions

Pin No.	Symbol	I/O	Function
1	VREF	O	Reference voltage output (Vdda/2)
2	MPXIN	I	Baseband (multiplexed) signal input
3	Vdda	—	Analog power supply (+5V)
4	Vssa	—	Analog ground
5	FLOUT	O	Subcarrier input (filter output)
6	CIN	I	Subcarrier input (comparator input)
7	TEST	I	Test input
8	XOUT	O	Crystal oscillator output (4.332MHz)
9	XIN	I	Crystal oscillator input (external reference input)
10	Vssd	—	Digital ground
11	Vddd	—	Digital power supply
12	MODE	I	Read mode setting (0:master,1:slave)
13	RST	I	RDS-ID/RAM reset (positive polarity)
14	RDDA	O	RDS data output
15	RDCL	I/O	RDS clock output (master mode)/RDS clock input (slave mode)
16	RDS-ID READY	O	RDS-ID/READY output (negative polarity)

JVC

VICTOR COMPANY OF JAPAN, LIMITED

AUDIO & COMMUNICATION BUSINESS DIVISION

PERSONAL & MOBILE NETWORK BUSINESS UNIT 10-1,1Chome,Ohwatari-machi,Maebashi-city,371-8543,Japan